

Comparison between uniaxial and biaxial test methods

## MECHANICAL PROPERTIES OF ETFE FOILS

Anticlastic minimal surfaces as elements in architecture

## SOFT.SPACES

REPORT

## TENSILE STRUCTURES MONTEVIDEO 2011

PROJECTS

Stone-age temple  
MEMBRANE ROOFS SHELTER

Olympic Stadium  
RECONSTRUCTION





# contents



## PROJECTS

PAGE

4 **France** OPEN-AIR THEATER  
1800m<sup>2</sup> suspended structure

4 **Germany** TEMPORARY ROOF  
STRUCTURE

9 **Ukraine** OLYMPIC STADIUM  
Reconstruction

16 **China** HOME OF THE FUTURE  
A showcase for future living

16 **Argentina** LA PLATA STADIUM  
High-light transmission membranes

17 **Germany** MEMBRANE ROOF Rhein-Galerie

18 **Malta** STONE-AGE TEMPLE  
Membrane roofs shelter

23 **Spain** TEXTILE WRAP A sustainable construction

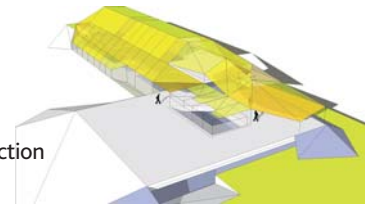

## RESEARCH

PAGE

6 **Mechanical properties of ETFE foils** Comparison  
between uniaxial and biaxial test methods

8 **S(P)EEDKITS**  
Rapid deployable kits  
as seeds for self-recovery

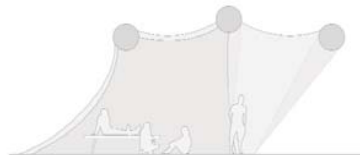

10 **SOFT.SPACES**

Anticlastic minimal surfaces  
as elements in architecture



## REPORT

PAGE

20 **Tensile Structures Montevideo 2011**  
4<sup>th</sup> Latin American Symposium Uruguay

## MISC

PAGE

19 **LITERATURE**

24 **INTERNATIONAL "TEXTILE STRUCTURE FOR  
NEW BUILDING 2011" COMPETITION FOR STUDENTS AT TECHTEXTIL**



Buro Happold  
www.burohappold.com

Canobbio S.p.A.  
www.canobbio.com

Ceno Tec  
www.ceno-tec.de

Dyneon  
www.dyneon.com

FabricArt  
Membrane Structures  
www.fabricart.com.tr/

Ferrari sa  
www.ferrari-textiles.com

Form TL  
www.Form-tl.de

Hightex GmbH  
www.hightexworld.com

Mehler Technologies  
www.mehler-  
technologies.com

Messe Frankfurt  
Techtextil  
www.techtextil.de

Naizil S.P.A.  
www.naizil.com

Saint-Gobain  
www.sheerfill.com

Sioen Industries  
www.sioen.com

Taiyo Europe  
www.taiyo-europe.com

technet GmbH  
www.technet-gmbh.com

Verseidag  
www.vsin dutex.de

## TensinewsINFO

### Editorial Board

John Chilton, Evi Corne,  
Peter Gosling, Marijke Mollaert,  
Javier Tejera

### Coordination

Marijke Mollaert,  
phone: +32 2 629 28 45,  
marijke.mollaert@vub.ac.be

### Address

Vrije Universiteit Brussel (VUB),  
Dept. of Architectural Engineering,  
Pleinlaan 2, 1050 Brussels, Belgium  
fax: +32 2 629 28 41

ISSN 1784-5688

All copyrights remain by each  
author

Price €15  
postage & packing included

Tensinews observes the current trend of expanding the use of technical membranes and foils in architectural projects. The variation in available materials is increasing, with respect to the appearance as well as the (structural) behaviour. The field of application is widening; more delicate, creative and intriguing projects are being built and more architects explore the possibilities of the technology of tensile surface structures, e.g. textile sustainable wraps, a large span stadium cover or a heritage shelter to protect an archaeological temple. A holistic approach is the way to go for these designs.

Numerous workshops, symposia - like the 4<sup>th</sup> Latin American Symposium on Tensile Structures in Montevideo - and conferences act as forums to discuss and disseminate the state of the art. The next TensiNet Symposium is planned for 2013. The younger generation is stimulated to hand in their student-projects at the bi-annual International "Textile Structure for New Building 2011" Competition at Techtextil.

There is also an increase in research projects to deepen the current knowledge, like testing and analysing the material properties of coated fabrics and foils, the study of deployable S(P)PEEDKITS for disaster relief or the exploration of anticlastic minimal surfaces as architectural and constructive components.

A new TensiNet Working Group on Pneumatic Structures is launched: Matthew Birchall ([matthew.birchall@burohappold.com](mailto:matthew.birchall@burohappold.com)) will be the leader of this Working Group.

The TensiNet association is part of the expanding topic of technical membranes and foils and hopes to further contribute to this evolution.

## CALL for Participants for TensiNet Working Group on Pneumatic Structures

Pneumatic Structures are increasingly being considered for a variety of applications in the built environment, from stadium roofs to bridges, and from permanent structures to deployable enclosures. The design, analysis and specification of these structures is often treated differently by different consultants in different countries, with occasional reliance upon qualitative and empirical experience, or applications from other industries.



TensiNet is launching a working group on Pneumatic Structures to consolidate the current best practise in this specialist field. It is envisaged that this working group will focus on analysis techniques, design processes, applicable standards and technical references, materiality options, and construction practicalities. Reference will be made to the existing working groups on ETFE and Analysis & Materials without duplicating their findings, of course.

The aims, scope and membership of the working group will be discussed at the start-up meeting to follow after the Annual General Meeting of TensiNet in Barcelona on 4<sup>th</sup> October 2011. Any interested parties who would like to participate should contact the leader of the working group, Matthew Birchall, at [matthew.birchall@burohappold.com](mailto:matthew.birchall@burohappold.com)

## Forthcoming Meetings

### TensiNet meetings in Barcelona, Spain

Thursday 4/10/2011

- 16:30 - 17:00 Welcome
- 17:00 - 18:00 Partner Meeting (2/2011)
- 18:00 - 19:00 Annual General Meeting
- 19:00 - 21:00 Working Group Meetings "Specifications" (Marijke Mollaert), "Analysis & Materials" (Ben Bridgens) and "ETFE" (Rogier Houtman)

**Location:** Technical University of Catalonia (UPC), Master Room, Building A3, Campus Nord, Jordi Girona 1-3, Barcelona, Spain

### CEN/TC250 WG5 \_ core group meeting in Paris, France

Wednesday 02/11/2011

- 10:00 - 16:00  
Core Group Meeting

**Location:**  
SFEC, 3rd floor, 65 Rue Prony,  
Paris, France

**Forthcoming Events** *International symposium* **IABSE-IASS 2011** London, UK 20-23/09/2011 ● *International conference on* **Structural Membranes 2011** Barcelona, Spain 05-07/10/2011 <http://congress.cimne.com/membranes2011/frontal/Dates.asp> ● *1st international* **Textile Architecture Seminar** Universidad de Castilla-La Mancha, Toledo, Spain 26-28/10/2011 ● *second international conference on flexible formwork* **icff 2012** Bath, UK 27 - 29/06/2012 [www.icff2012.co.uk](http://www.icff2012.co.uk)







# Open-air theater

Colmar, France

## 1800M<sup>2</sup> SUSPENDED STRUCTURE

### Context

The City of Colmar wanted to cover the open-air theater of its Exhibition Park in a lasting and esthetic way. The challenge was to cover the existing Eastern and Western tiers by installing a textile cover fixed on a metal framework with particularly short delays and taking into account the existing equipment

and the constraints inherent to the site. For example, the theater is located very close to the Colmar airport and part of the construction stands inside the area concerned by the planes' taking-off and landing operations. The solution chosen by ESMERY CARON was to install very big textile cones suspended at 20m above the theater stands.

### Structure and installation

The plan dimensions of the two covering modules are about 55m by 2 X 65m, i.e. 2 textile covers of 900m<sup>2</sup> and 2.2 tons each. The metal structure supporting the tension fabric cover is mainly made of two triple masts of 3.5 tons each, holding a 135m long cable placed at an alti-

tude of about 20m. The textile covers are completely independent from the existing open-air theatre structures by being tensioned on main cables (56mm in diameter). The metal frames were treated by bath galvanization and bolted on-site. Erection of the elements was performed using a telescopic crane

## KIEFER TEXTILE ARCHITEKTUR

# Temporary roof structure

Festung Ehrenbreitstein, Germany

### Context

Built in early 19th century the "Festung Ehrenbreitstein" is a landmark in Koblenz, located opposite of the famous "Deutschen Eck" between Rhein and Mosel. In one of the moats of the historical "Festung Ehrenbreitstein" a main stage and stands for the Bundesgartenschau 2011 (BUGA 2011) have been located (Fig. 1). All kind of concerts will take place from April until October 2011. The moat called "Retiriergraben" is about 24m to 27m wide and 100m long. The slope of the "Graben" ends in east direction at the "Landbastion", is bordered to the North by "Kurtine" (both 25m high ancient walls) and to the South by a ramp in front of "Contregarde Rechts", which is opposite inclined to the "Retiriergraben", from 4 to 12m height (Fig. 2). The moat opens up upwards. Client and investor was BUGA 2011, the owner is "Bundesland Rheinland-Pfalz".



Figure 1. Aerial view on the main stage © PP Koblenz

### Project

Kiefer. Textile Architektur provided a range of architectural solutions, until the client's and owner's requirements, which changed

during the design process, had been achieved. The final brief was to create a temporary covering for a stage of 8 to 12m and approximately 800 spectators in a

way that no attention is taken away from the ancient masonry of the surrounding buildings and the new construction is not attached to the old (Fig. 3).



installed close to the building site. The fabric was made in the workshop and folded in a specific order allowing a very precise on-site installation taking into account the need for working at heights and the dimensions of the construction. The fittings and various cables are made of galvanized steel with a metal core. Endings are of the rigid fork or threaded end types.

Figure 1. Overview

Figure 2. External and internal view of the two covering modules

Figure 3. Installation

 **Olivier Dufour**  
 [olivier.dufour@esmerycaron.com](mailto:olivier.dufour@esmerycaron.com)  
 [www.esmerycaron.com](http://www.esmerycaron.com)

Project Name:	Covering of the open-air theater, Exhibition Park
Location address:	Colmar, France
Function of the building:	Outdoor facilities
Client:	Colmar City
Year of construction:	July 2009
Project Manager:	Colmar City Architecture Department
Metal framework:	ACML
Supplier of the membrane material:	FERRARI 1502 T2 1500g/m <sup>2</sup> - EN ISO 2286-2 standard
Membrane and framework Consultant:	ARCORA
Supplier of the membrane:	ESMERY CARON
Installation of the membrane:	ESMERY CARON and EVEREST (3 weeks for a fitting team of 7)
Covered surface:	1800m <sup>2</sup>

The obvious solution was to build a roof

- remarkable higher than the ramp, to invite looking from the ramp into the stage;
- horizontally, in order to accentuate the falling and ascending lines along the ramp wall;
- with respectful space between masonry and roof edge;
- light and stringent seemingly, symmetrical main structure;
- translucent and smooth shaped elements.

Six portal frames in a grid of 7m, designed by three girder trusses, achieve minimum truss diameters. The horizontal upper girder cantilevers at both ends, in order to base aside of existing foundations. Excavations for the new precast concrete units had to be limited to max. 50cm. The vertical trusses vary from 11 to 15m height. Their lowest part is the adjusting element. The stiffing of the structure in longitudinal direction is induced by vertical cross bracing of each bay, in cross direction by portal frames. The fabric covers six bays of 7x 22m. Each bay gets an accentuated shape through two valley belts, which divide the bay into three elongated areas. The middle one shows a classical slightly barrel-shaped form. It effects a reduction of the visual

presence of the upper girder. To reduce any imperfections in the fabric there is no assembling along the top girder but two welded keder strips to hinder horizontal movement. At both end frames the fabric is clamped by standardized keder-clamping profile from Tennect to allow for unpunched linear fixation. Membrane edges are framed with belts to underline the temporary character.

The valley belts are slightly curved to increase the dynamic appearance of the single bays. The belts are fixed to a rotatable supported bail consisting out of steel tubes. These bails are used to tension the membrane. Due to the various angle at the fixation points of tie down tension struts a standardized ready-made product from Tennect was used. The roofing structure was finally completed one day before opening ceremony at 15th of April. The complete design, engineering and cutting pattern was carried out from Michael Kiefer, Tobias Lüdeke and Manfred Schieber at Kiefer. Textile Architektur.

 **Michael Kiefer**  
*Kiefer. Textile Architektur.*  
*Architekten und Ingenieure*  
 [info@k-ta.de](mailto:info@k-ta.de)  
 [www.k-ta.de](http://www.k-ta.de)



Figure 2. View from the ramp to the main stage

Figure 3. View main stage © Kiefer. Textile Architektur.

Name of the project:	Temporary roof structure
Location address:	Festung Ehrenbreitstein, Germany
Client (investor):	BUGA 2011 and Rheinland-Pfalz
Function of building:	Temporary roof of main stage and stand
Type of application of the membrane:	Valleycable Saddleshaped
Year of construction:	2011
Architects:	Michael Kiefer, Sebastian Fey Kiefer. Textile Architektur.
Structural engineers:	Tobias Lüdeke, Manfred Schieber Kiefer. Textile Architektur.
Consulting engineer for the membrane:	Tobias Lüdeke Kiefer. Textile Architektur.
Main contractor & contractor for the membrane:	Ceno-Tec
Supplier of the membrane material:	Verseidag
Manufacture and installation:	Ceno-Tec
Material:	Verseidag B1951, PVC/ PES Typ 1
Covered surface (roofed area):	ca. 800m <sup>2</sup>
Membrane assembling system:	Tennect (Carl Stahl)



UNIAXIAL

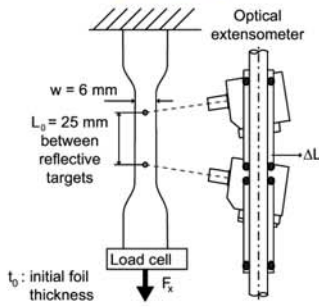

(A1) Load cell:  $s_x = \frac{F_x}{wL_0}$

Extensometer:  $e_x = \frac{\Delta L}{L_0}$

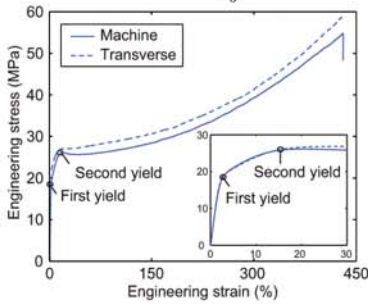

(B1) True strains:  $\epsilon_x = \ln(1 + e_x)$   
 $\epsilon_y = \epsilon_z = -\nu \epsilon_x$

True stress:  $\sigma_x = \frac{s_x}{\exp^{-2\nu \epsilon_x}}$

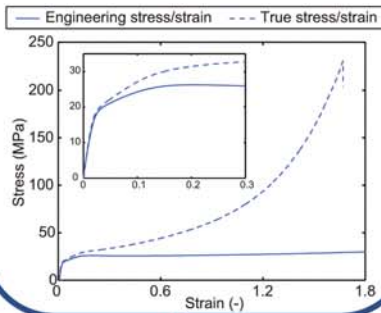

BIAXIAL (PLANAR)

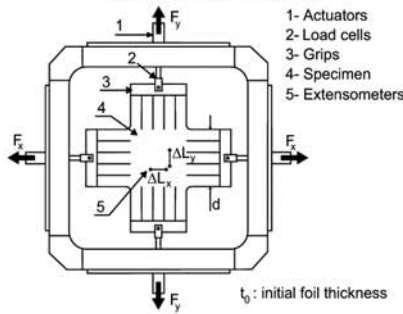

(A2) Load cells:  $s_x = \frac{F_x}{dL_0}$ ;  $s_y = \frac{F_y}{dL_0}$

Needle extensometers:  $e_x = \frac{\Delta L_x}{L_{x0}}$ ;  $e_y = \frac{\Delta L_y}{L_{y0}}$

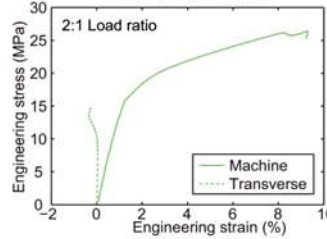
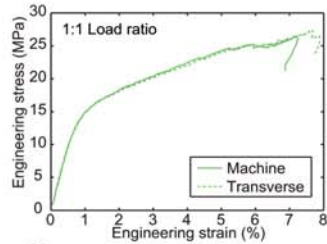

(B2) True strains:  $\epsilon_x = \ln(1 + e_x)$ ;  $\epsilon_y = \ln(1 + e_y)$

True stresses:  $\sigma_x = \frac{s_x}{\exp^{(\epsilon_y + \epsilon_z)}}$ ;  $\sigma_y = \frac{s_y}{\exp^{(\epsilon_x + \epsilon_z)}}$

with  $\epsilon_z = \frac{\nu}{\nu - 1} (\epsilon_x + \epsilon_y)$

BURSTING TEST

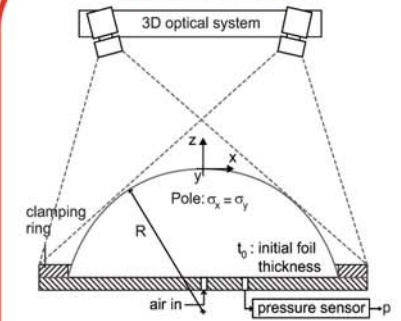

(A3) Digital image correlation:

True strains at pole:  $\epsilon_x$ ;  $\epsilon_y$

Pressure sensor: air pressure  $p$

(B3) Assumption: incompressible material:

$\epsilon_z = -\epsilon_x - \epsilon_y$

Therefore, the foil thickness at pole is:

$t_p = t_0 \cdot \exp^{-\epsilon_x - \epsilon_y}$

Digital Image Correlation:

Bubble radius  $R$  by surface fitting

Based on pressure vessel theory:

True stresses at pole:  $\sigma_x = \sigma_y = \frac{pR}{2t_p}$

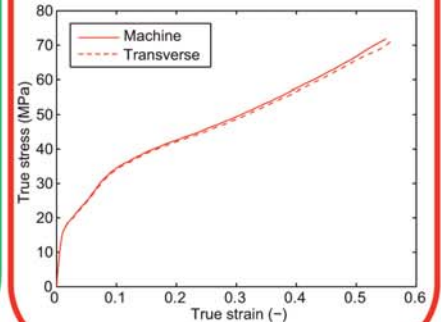

COMPARISON

(C) Von Mises equivalent stress  $\sigma_{eq} = [\sigma_x^2 + \sigma_y^2 - \sigma_x \sigma_y]^{1/2}$

Von Mises equivalent strain  $\epsilon_{eq} = \frac{1}{1+\nu} \left[ \frac{1}{2} [(\epsilon_x - \epsilon_y)^2 + (\epsilon_y - \epsilon_z)^2 + (\epsilon_z - \epsilon_x)^2] \right]^{1/2}$

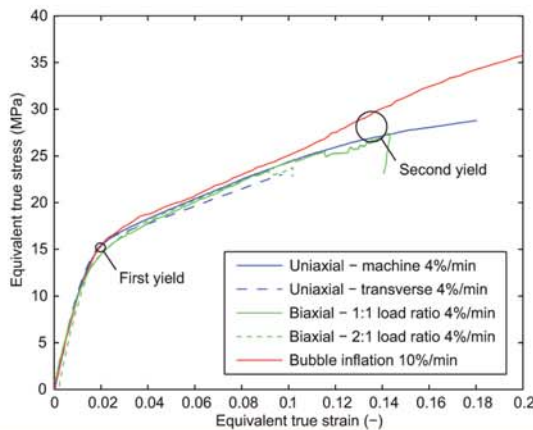

Notation:

s: engineering stress

e: engineering strain

σ: true stress

ε: true strain

x,y: material plane

z: direction normal to the material plane

# Mechanical properties of ETFE foils

## Comparison between uniaxial and biaxial test methods

ETFE foils have increasingly been used since the 1980's for roofs and claddings [1-4]. Their excellent light transmission capability combined with their lightness and flexibility has broadened the scope of large transparent structures. The low weight properties of ETFE foils allow the design of structures which would have been impossible to build with conventional materials such as glass.

ETFE is a polymer and therefore it exhibits non-linear stress-strain behaviour as well as rate- and temperature-dependency [5]. Usually its behaviour is derived from uniaxial tensile tests [3-5]. In that case the behaviour is often measured in both machine (extrusion direction) and transverse direction. There is also an increasing interest for biaxial tests because they allow the observation of the material response under biaxial stresses as occurring in a tensile structure. In particular bursting tests have become popular during the last years [6] as they enable very large biaxial deformations. However, the benefits of biaxial testing over uniaxial testing have not been clearly demonstrated so far for ETFE foils. Three tests methods are here compared [7]: uniaxial tension, biaxial extension of cruciform specimen and bursting test. The study is focused on the determination of the material mechanical properties from the experimental data. After an adequate post-processing these data are compared and the advantages of each test method are discussed.

### Preliminary definitions

The mechanical behaviour of materials is described by relationships between stresses and strains. There exist however different definitions, the most commonly used being the engineering stress  $s$  and the engineering strain  $e$ . They are actually simplified formulations and are only valid under infinitesimal strains as they always refer to the material initial configuration. If the strains exceed a few percents then the true stress  $\sigma$  and true strain  $\varepsilon$  must be used. They represent the true material behaviour which is used in finite element analyses. The true stress accounts for change in cross-sectional area by using the instantaneous sample area. The true strain accounts for an incremental sample deformation where the new strain depends on the updated shape. The comparison between both definitions is illustrated in the part (B1) of the summary picture for the uniaxial tension of an ETFE foil. The engineering stress and strain are accurate enough in the initial linear part. Above 2% of strain the difference with the true stress and strain becomes significant.

### Test procedures

#### • Uniaxial tension

Specimen shape: standard dumbbell

Control: traverse displacement

(A1) The tensile load is measured with a load cell while an optical extensometer measures the distance between two targets, allowing the calculation of the engineering stress and strain. The obtained stress-strain curve shows the non-linear behaviour of ETFE foils. After an initial linear part, it exhibit two points where

the stiffness significantly decreases denoted as two yield points. The material undergoes very large deformations up to more than 400% at failure. One can also mention that the behaviour in the machine and transverse direction is very similar.

(B1) The tensile true stress and strain can be calculated from the engineering stress and strain. The Poisson's ratio  $\nu$  is required. It is however not obtained from the uniaxial test, unless a strain measurement is operated in the direction orthogonal to the loading. One can either assume an incompressible material behaviour ( $\nu=0.5$ ) or use a typical value for ETFE ( $\nu=0.43$  [7]). With this definition of stress and strain the increase of stiffness in the second half of the curve is even more pronounced. It is due to the reorganization in the polymer structure, where the molecular chains are reoriented in the loading direction. As a result the material is no longer isotropic.

#### • Biaxial extension of cruciform specimens

Specimen shape: cruciform

Control: load on each grip

(A2) The load is measured for each grip with a load cell and two needle extensometers measure the strain in the central area of the sample. It can be seen from the results that the failure occurs at small strains, which is due to the particular geometry of the sample. This early failure of the specimen at about 7% of strain is the main disadvantage of this method as it is not representative of the strains that the foil undergoes under large biaxial stresses. Biaxial machines however allow the application of different load ratios on the sample contrary to the bursting test.

(B2) The biaxial true stress and true strain can

be calculated from the engineering stress and strain. In that case the Poisson's ratio can be obtained from the biaxial tests if at least two load ratios are explored.

#### • Bursting test

Specimen shape: circular

Control: air pressure during the inflation

(A3) The material behaviour is observed at the pole where a 1:1 load ratio is obtained. The biaxial true strains at the pole are directly measured by a 3D optical system using digital image correlation. The air pressure is measured by a pressure sensor. Without post-processing no data is obtained as there is no mean of measuring the stress in the material.

(B3) The true stresses at the pole are calculated based on pressure vessel theory. The bubble radius is estimated from the bubble shape measured with the 3D optical system using a surface fitting. The foil thickness at the pole is estimated using the initial thickness and the measured in-plane strains assuming that the material is incompressible (constant material volume). With the bursting test much higher biaxial strains are reached. In that case failure occurs at about 75% of engineering strain (true strain of 0.56). Therefore the bursting test must be used in order to observe the behaviour of the material and its failure under large biaxial stresses.

### Comparison

It is not possible to directly compare the stress-strain curves that have been previously presented. Each of these curves represents the relationship between only one stress component and one strain component. In reality, the material behaviour is defined by a relationship between the stress tensor and the strain tensor. If one assumes a plane stress state without shear then for an isotropic material it is described by 3 equations:

$$\varepsilon_x = \frac{1}{E} \sigma_x - \frac{\nu}{E} \sigma_y$$

$$\varepsilon_y = -\frac{\nu}{E} \sigma_x + \frac{1}{E} \sigma_y$$

$$\varepsilon_z = -\frac{\nu}{E} (\sigma_x + \sigma_y)$$

Under biaxial loading the strain in one direction is not only related to the stress applied in that direction but also to the stress applied in the

orthogonal direction due to the Poisson's effect. As far as multidirectional stresses are concerned, the Von Mises formulas can be used to combine the stresses and strains into an equivalent stress and an equivalent strain. The corresponding curves are presented in the summary figure (C) for two uniaxial tests, two biaxial tests and one bursting test performed at room temperature at almost identical strain-rates. Results are very similar up to the second yield stress. Above the second yield stress the large deformations occurring in the material change its microstructure and therefore its mechanical properties. The material becomes anisotropic and its behaviour depends on the applied loading.

## Conclusion

It has been shown that if an adequate post-processing is used then similar stress-strain curves are obtained up to the second yield stress with uniaxial and biaxial test procedures. Therefore uniaxial test can be used for measuring the material initial behaviour as they are very easy to perform and do not require much material and time. If the plastic behaviour or the failure of the material must be investigated then biaxial stresses must be applied. In that case the bursting test is the most suitable method as it allows very large biaxial deformations. This method is however limited to a single load ratio (1:1 for a circular sample). In order to apply different load ratios a biaxial test machine can be used.

✍ *Cédric Galliot*  
✉ [cedric.galliot@empa.ch](mailto:cedric.galliot@empa.ch)  
✍ *Rolf Luchsinger*  
✉ [rolf.luchsinger@empa.ch](mailto:rolf.luchsinger@empa.ch)

Center for Synergetic Structures  
🌐 [www.empa.ch/css](http://www.empa.ch/css)

## REFERENCES

- [1] K. Moritz. Bauweisen der ETFE-Foliensysteme. *Stahlbau* 2007;76(5):336-342.
- [2] S. Robinson-Gayle, M. Kolokotroni, A. Cripps, S. Tanno. ETFE foil cushions in roofs and atria. *Construction and Building Materials* 2001;15:323-327.
- [3] Y. Xiang, J. Li. Calculation and design of ETFE membrane structures. In: *Proceedings of the IASS Symposium, Beijing, 2006*.
- [4] M. Wu, J. Lu. Experimental studies on ETFE cushion model. In: *Proceedings of the IASS Symposium, Mexico, 2008*.
- [5] K. Moritz. Time-Temperature-Shift (TTS) of ETFE-foils. In: Kröplin B, Oñate E, editors. *International Conference on Textile Composites and Inflatable Structures, Structural Membranes 2009*. CIMNE: Barcelona, 2009.
- [6] L. Schiemann, S. Hinz, M. Stephani. Tests of ETFE-foils under biaxial stresses. In: Kröplin B, Oñate E, editors. *International Conference on Textile Composites and Inflatable Structures, Structural Membranes 2009*. CIMNE: Barcelona, 2009.
- [7] C. Galliot, R.H. Luchsinger. Uniaxial and biaxial mechanical properties of ETFE foils. *Polymer Testing* 2011;30(4):356-365.

# S(P)EEDKITS

## Rapid deployable kits as seeds for self-recovery

The project 'S(P)EEDKITS', which will start in 2012, will research rapid deployable kits as seeds for self-recovery in disaster affected sites. A multidisciplinary team, consisting of different organizations throughout Europe, will develop a new emergency system of modular rapid deployable shelters, facilities and medical care. The kits must be transportable, modular and adaptable, must have a low cost and must be high-tech in their conception but low-tech in use (Fig. 1 gives an example of a feasible kit. However the implementation of the kit, in the context of disaster relief shelters, still needs to be investigated). Current kits will be scanned with regard to large transportation volumes and/or heavy weight. Out of this knowledge, new concepts will be developed to drastically reduce the transportation volume and weight. The goal of these kits will be to provide temporary infrastructure, to establish the necessary temporary services and to limit the damage to economic and social fabrics. The kits should provide infrastructure for different purposes, e.g. a hospital, a communication centre, water facilities or sanitation units. Also four different basic shelter kits will be designed and analyzed:

- *A lightweight safe house unit*: this shelter gives coverage for the very first hours and need to be deployed by the communities
- *A collective unit*: a shelter which is usable for diverse purposes
- *A family house unit*: this shelter will be used in the transitional period and later, it can be referred to as the first version of a real house
- *A robust warehouse unit*: a somewhat larger shelter for the humanitarian organizations, it can be used for storage, offices, medical centers, etc.

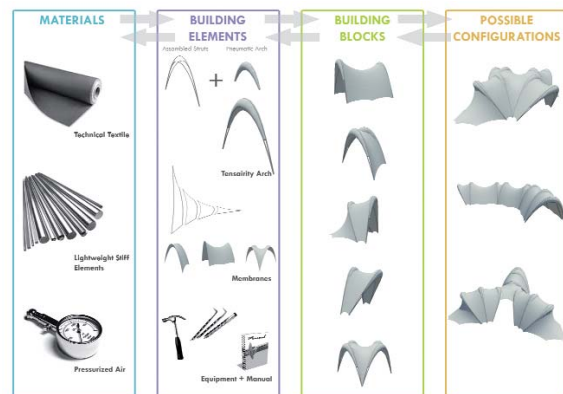

Figure 1: First steps in the design of a possible disaster relief shelter kit

The need for these kits becomes evident when thinking about the many disasters, both nature- and man-made, that occur worldwide. As a result, countless people are rendered homeless without any medical care, sufficient and clean water, decent sanitation or energy supply. In case of such an emergency situation, humanitarian organizations (like the Red Cross, Red Crescent Movement and Médecins Sans Frontières) emergency response units to rebuild these affected sites. These units are sent out immediately after a disaster strikes. Each unit has his own field of expertise and consists of trained people and the necessary equipment (the 'kit') needed on site. The S(P)EEDKITS project wants to develop novel 'kits' that can be pre-positioned and mobilized more quickly and easily than existing ones.

*The S(P)EEDKITS project will be a collaboration between: Centexbel (BE), Shelter Research Unit (LU), Netherlands Red Cross (NL), Sioen Industries (BE), Vrije Universiteit Brussel (BE), Technische Universiteit Eindhoven (NL), Politecnico di Milano (IT), De Mobbiele Fabriek (NL), Waste (NL), Practica (NL), D'Appolonia (IT), Internationales Biogas und Bioenergie Kompetenzzentrum (DE), Millson BV (NL), MSF Nederland (NL) and Norwegian Refugee Council (NO).*

✍ *Jan Roekens - Vrije Universiteit Brussel*  
✉ [jan.roekens@vub.ac.be](mailto:jan.roekens@vub.ac.be)

✍ *Guy Buyle - Centexbel*  
✉ [guy.buyle@centexbel.be](mailto:guy.buyle@centexbel.be)



## RECONSTRUCTION

# Olympic Stadium

### Kiev, Ukraine

#### Introduction

Over the last decades Hightex has been dedicated to the construction of innovative fabric roofs for sporting venues. One of the stadium projects for the EURO 2012 in the Ukraine and Poland is the Olympic Stadium in Kiev, which is currently undergoing a comprehensive revitalization. The design for the reconstruction of the stadium respects the historical building with its significant filigree prestress concrete upper tier tribunes from 1968, by arranging the superstructure of the new roof system detached and with a distance to the existing seating bowl.

The most prominent part of the "Kiev Central Stadium" will be enclosed with a new delicate glazing façade and, like an exhibit in a glass cabinet, will be put in perspective with lighting. This is how the architect von Gerkan, Mark and Partner (gmp) describe their design. With its fabric roofing system shaped by filigree flying struts into an ocean of conicals covered with light domes the Olympic Stadium should receive a unique and distinctive identity as an urban landmark within the texture of the city centre of Kiev. The main structural system of the roof derives from the spoke wheel principal. It consists of two outer compression rings, steel plate box girders, which rest on the 80 kinked columns, also made of tapered steel box girders. 80 cable trusses of upper and lower radial cables, coupled with hanger cables build up a light cable net, which are anchored into these compression rings and meet at the centre in a tension ring. The tension ring encases approximately the playing pitch. The horizontal forces are balanced out between the outer compression rings and the inner tension ring. The vertical forces are

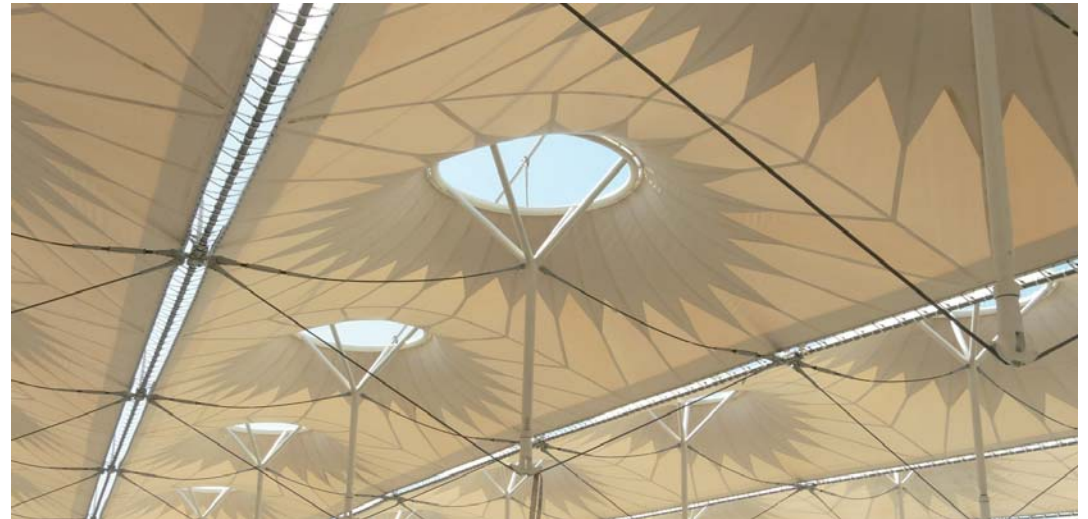

transferred from the cable net into the 80 columns and into the foundations. 80 axes are very uncommon for stadium roof constructions. Similar projects usually make do with about half the number of axes.

One of the reasons for this design was the original material choice of the main membrane. First concepts envisioned the use of a single layer of ETFE foil. It has much lower structural capacity than typical coated fabrics, which are usually used for stadium roofs. While the fabrication and installation of the steel columns was already under way, the material choice of the highly transparent foil was dismissed over the course of the planning. The 80 columns still dominate the overall impression of the architecture of the stadium and will impress a unique character onto the stadium. The roof cover, the translucent membrane field elements, will now be made of PTFE coated Glass fabric. Eight flying struts in each bay impress a series of conical shapes into the main membrane. These flying struts flare up like a funnel and the main membrane is connected to the top rings of the flying struts. The round

openings between 2.5m to 3.2m diameter are covered with light domes spanned with ETFE foil. This generates a unique translucent roofing landscape with in total 640 light spots. For this project Hightex is responsible for the cable structure and membrane roof.

#### Cable structure (Fig. 1 to Fig. 5)

The ten ring cables are 115mm diameter also fully locked galvan cables and have a total length of about 469m each. They are bundle into two layers of 5 cables each and

connected to the so called ring cable connectors. These are 2.5t castings, which have two vertically arranged cleats, connect the upper and lower radial cables to the ring cables. The upper and lower radial cable, also fully locked galvan cables are interconnected with 8 hanger cables each build up the 80 cable trusses. The cables are fabricated with fork terminals at each end. One end connects to the ring cable connector and the other end connects to cleats at the upper and lower compression rings.

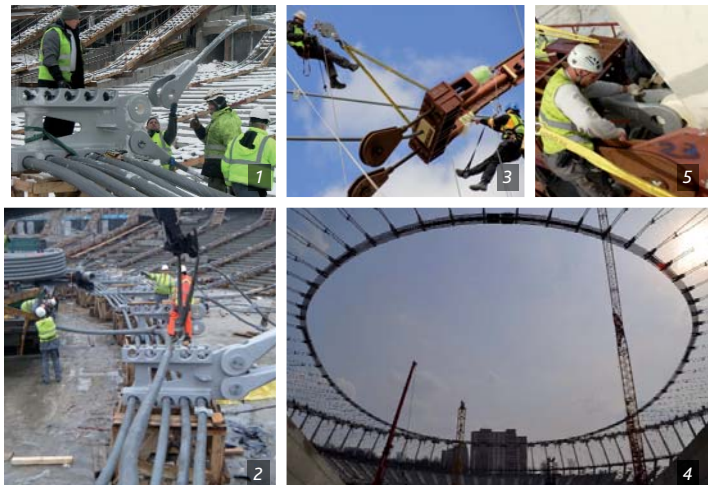

**Installation of the cable structure**

Figure 1. Connection of upper radial cable and ring cable

Figure 2. Layout of ring cable

Figure 3. Lifting of spreader bar

Figure 4. Cable net roof construction

Figure 5. Pinning of fork terminal

For the installation the radial cables and ring cables are laid out in the stadium bowl. The open ends of the radial cables are fitted with temporary spreader bars to take on the lifting equipment. The upper radial cables are pulled towards the upper compression ring with strand jacks and pinned. This process will lift the cable net completely off the ground. Then the last 1.5m of the lower radial cables are pulled with the threaded bars and hollow hydraulic cylinders towards the lower compression ring until all cables can be pinned. This process is called the "big lift" and takes about 30 days.

#### Membrane structure

(Fig. 6 to Fig. 11)

For the next installation step the membrane roof panels are fitted onto the completely stressed cable net. Each of the 80 bays consists of about 600m<sup>2</sup> PTFE/Glass membrane panels with an approximate weight of one tone. The membrane

fields will be cut from the virgin roll material, welded and assembled ready-to-install off site in the factory. They get packed, shipped to site and directly lifted onto the roof. The membranes are unfurled from the rolling rack on the lower compression ring. The membrane is then connected at the circular cut outs to the already positioned but lowered flying struts. The final shape and prestress is brought into the membrane by lifting the flying struts into their final position. This process is assisted by hydraulic jacks at the footing of the flying struts. The roof structure is completed after all the 640 light domes are mounted.

-  *Gregor Grunwald*  
 [gregor.grunwald@hightexworld.com](mailto:gregor.grunwald@hightexworld.com)
-  *Markus Seethaler*  
 [markus.seethaler@hightexworld.com](mailto:markus.seethaler@hightexworld.com)
-  [www.hightexworld.com](http://www.hightexworld.com)
-  *Pictures: Hightex GmbH*

Name of the project:	Olympic Stadium Kiev
Location address:	City of Kiev, Ukraine
Client (investor):	Olympic National Sports Complex, Ukraine
Function of building:	sport stadium
Year of construction:	2010-11
Architects:	gmp • Architekten von Gerkan, Marg und Partner, Personal Creative Architectural Bureau Y. Serjogin
Structural engineers:	SBP – Schlaich Bergemann und Partner
Manufacture and installation of cable net and membrane:	Hightex GmbH
Supplier of the membrane material:	Verseidag-Indutex GmbH
Material:	PTFE-Glass
Covered surface (roofed area):	approx. 45.000m <sup>2</sup>



#### Installation of the membrane

Figure 6. Beginning of membrane installation  
Figure 7. Roof view from below  
Figure 8. High point installation

Figure 9. Roof top view  
Figure 10. Different stages of high point installation  
Figure 11. Installation of the high point clamping profile

# Anticlastic minimal surfaces as elements in architecture

## Introduction

On the basis of the research of Frei Otto and his team at IL (University of Stuttgart) and the resulting exceptional pioneer constructions, building with textiles as an alternative to traditional materials like wood, stone, steel, glass, and concrete was rediscovered during the last decades. Deriving from self organizing forms of Minimal Surfaces, prestressed, spatially curved Membrane Structures were up to today mainly used for wide span, lightweight-structures. For this reason membrane structures tend to be seen from a structural or material point of view only. In contrast to our right-angled, conventionally built environment the desire for fluent "soft" spaces in architecture cannot be overseen any more. The possibility to create light and fluent spaces as a symbiosis of form and structure offers new qualities and chances in the architectural design of residential or office buildings for example.

## Subject

This article presents the overview of the research on spatially curved Minimal Surfaces that considers the infinite possibilities of membrane forms as elements in architecture in combination with common building-technologies and shows new capabilities in designing and creating spaces. Seen as an element in the design of architecture these anticlastic, fluent forms caused by structural conditions, follow the rules of formfinding in its initially (by Frei Otto) defined sense. Very often we misuse the term „formfinding“. What Architects mostly mean and do is a man controlled process of shaping - a process that happens on a consciously controllable and formal level. In contrast to the man-controlled process of shaping, forms that are arising from self organizing processes can only be influenced by the design of their boundaries. The form itself can only be found and represents the result which cannot be manipulated. The architect finds himself in the unusual position of a creative "formfinder" instead of the "shaper". The fluent forms of Minimal-Surfaces are fascinating by their variety, structural performance, reduction to the minimal in terms of material use and resources and their special fashion-resistant aesthetics.



# SOFT.SPACES

Together these parameters represent the common basis of a potential design or design concept and characterize its grade of sustainability.

## Objectives

Since self organizing processes follow precise rules and contain optimization by their nature descriptions and especially in architecture illustrations of these rules can be used as design tools<sup>[7]</sup>. To find out about the chances for an architecture between „hard“ and „soft“ morphology, basic research on the systematic determination of very different boundaries - the interface between membranes and common construction technologies - enables the opportunity to analyze anticlastic Minimal Surfaces regarding form and curvature. Vice versa we get an idea of the correlation between 3d-curvature, deflection and determined boundary and further on an idea of formal and structural behavior. In this context the assessment and visualization of the Gaussian curvature, which were adapted especially to this research, played an important role.

## Special Specifications

### 1 Minimal surface

All experiments are restricted to forms that can be derived from the results of soapfilm models – the Minimal Surface. As long as boundary conditions are not changed, Minimal Surfaces can be arranged as a unity arbitrarily in space without changing its form/geometry.

### 2 Interface

Linear, maximal 2dimensionally curved, bending resistant, line supported boundaries

turned out to be the ideal interface between membranes and common construction technologies. All further experiments were restricted to boundaries of that kind.

### 3 Membranes as an integrative element

Membranes are seen as an integrative component of architecture and are directly connected to other elements of common construction methods. In terms of structural effectiveness the surfaces themselves are considered to be highly efficient by their spatial curvature but not to be load bearing elements for other structural members although newest approaches in the author's research are dealing with this possibility.

## Investigations

The range of exploration covers wall-like elements, T-shaped connections, solutions for vertical, horizontal and free corners and the tubular entities of the Catenoid.

## Methods

Besides physical (Fig. 1) and soapfilm models (Fig. 2) mainly digital experiments (Fig. 3) were used for the interpretation and the verification of results. Soapfilm models were mainly considered to fulfill a control function. Digital models were essential for the analysis and evaluation of forms (section curves, their diagrammatic overview, analysis of angles in space,...) of Minimal Surfaces. In this context the assessment and visualization of the Gaussian curvature (Fig. 4), which were adapted especially to this research, made it possible to compare and to draw one's conclusions on different forms and their structural behavior.

## Results of investigation

The results of physical, soapfilm and mainly digital experiments show surprising and partly new correlations between form and boundary proportions and so far unknown rules of the self organizing processes of Minimal Surfaces – especially in the field of the Catenoid. The overview and the comparison of the results as well as the possibility of a targeted selection can therefore be the basis for creative applications.

### 1 Minimal surfaces between straight lines and boundaries consisting of segments of a circle

All experiments related to this series (Fig. 5) show, that for this boundary condition it is not possible to find a fully anticlastic curved Minimal Surface. Those surfaces which show few flat areas are generated within a relatively small spectrum of boundary conditions. They concentrate on boundary conditions consisting of semicircles with a diameter that corresponds to the distance of the boundaries. Independent of the amplitude of the curved boundary Minimal Surfaces tend to be flat in the near of the straight line boundary.

Experiments show that in average up to 96% of the horizontal deflection that was given by the curved boundary is disappearing halfway between the upper and lower boundary. Horizontally shifted boundaries (Fig. 6) can be interesting from the architectural point of view. But in terms of anticlastic Gaussian Curvature this always means a further increase of flat areas.



Figure 1. Physical study model - showing catenoids between shifted circular rings

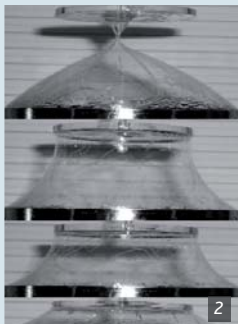

Figure 2. Sequence of Soapfilm Models

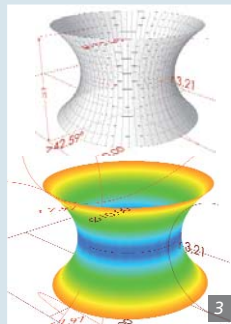

Figure 3. Digital model of a catenoid between circular rings and Visualization of Gaussian Curvature

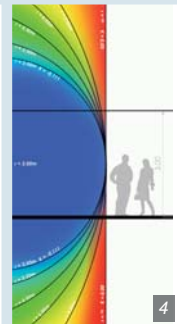

Figure 4. Special unification of assessment and visualization of the Gaussian curvature for this research

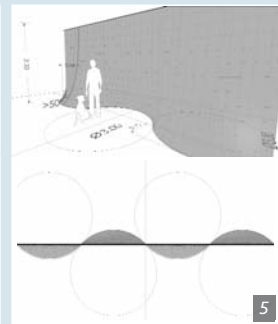

Figure 5. Minimal Surfaces between straight lines and boundaries consisting of segments of a circle

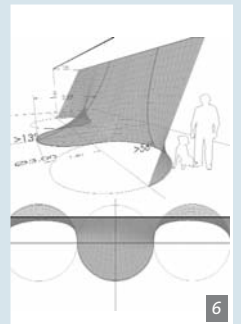

Figure 6. Horizontally shifted boundaries

## 2 Minimal surfaces between boundaries consisting of segments of a circle

In this case the boundaries of wall like Minimal Surfaces can have the same direction or they can be arranged inversely. Horizontally shifted boundaries represent special cases and show interesting architectural effects. The horizontal offset can be in longitudinal, cross or diagonal direction.

Minimal Surfaces between boundaries consisting of segments of a circle in the same direction

Boundaries that are curved in the same direction (Fig. 7) generally effect strong anticlastic curvature of Minimal Surfaces. Boundary conditions consisting of semicircles with a diameter that equals the distance of the boundaries can be qualified as 100% spatially curved. Section lines show the smallest circle of curvature exactly on half height and harmonic development of the surfaces (Fig. 8).

Minimal Surfaces between boundaries consisting of inversely arranged segments of a circle

Curved and inversely arranged boundary conditions effect anticlastic curvature covering most of the surface, even if the boundaries have little oscillation from the longitudinal axis. The mostly curved surface can be developed with boundaries consisting of semicircles with a diameter of 2/3 of the distance of the boundaries (Fig. 9). Areas with little spatial curvature can first of all be found exactly at the maxima of boundary curvature and on half height. Starting from the ideal case these flat areas increase with increasing as well as with decreasing diameters of the base-circles. Surfaces arising from boundary conditions with base-circles bigger than the height show

Figure 7. Boundary configurations consisting of segments of circles having the "same direction"  
Figure 8. Vertical section of digital models and their circles of curvature, all having their center at half height.

Figure 9. EM KK 2/3\_ 1,00HK ggs  
Figure 10. EM KK 2/1\_ 0,50HK ggs  
Figure 11. EM KK 1/2\_ 1,00HK ggs  
Figure 12. Horizontal Corner  
Figure 13. Vertical Corner  
Figure 14. Free Corner

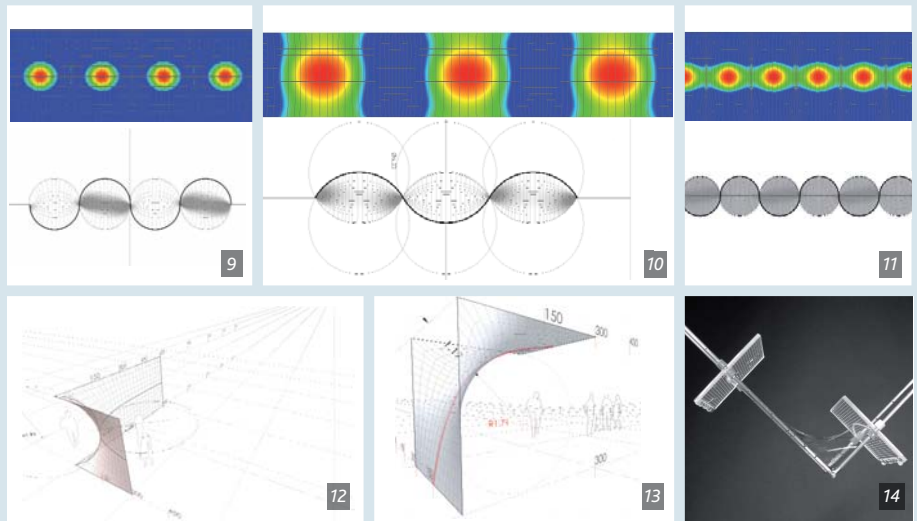
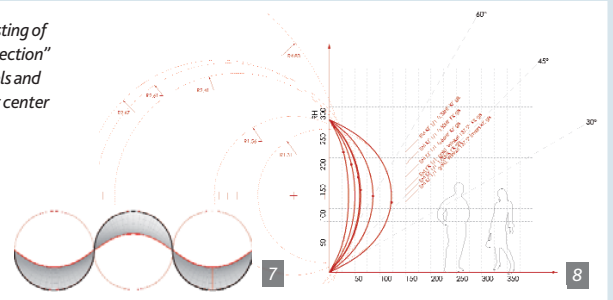

flattened vertical stripes (Fig. 10) whereas flattened horizontal stripes (Fig. 11) appear with boundaries consisting of segments of circles with less than the height.

## 3 Membranes corners

Regarding corner solutions, boundaries can be arranged horizontally (Fig. 12) or vertically (Fig. 13). The free corner (Fig. 14) describes a special case. The vertical and free membrane corner will not be described in this article..

### Horizontal membrane Corner

All executed experiments with horizontal right-angled corners show almost constant surface curvature (Fig. 15) and deflection in the area of

the corner (Fig. 16). This happens independently from the leg length and from being arranged symmetrically or asymmetrically. The section lines of digital models are congruent (Fig. 17). Leg length being shorter than the height cause surfaces with little anticlastic curvature. Surfaces of maximum spatial curvature in all areas can be achieved with a ratio 1/1 to 3/2 of leg length/height. Increased leg length causes areas with little anticlastic curvature at the end of the legs.

## 4 T-connection

Surfaces meeting in a T-connected boundary (Fig. 18) generate a Y-intersection (Fig. 19).

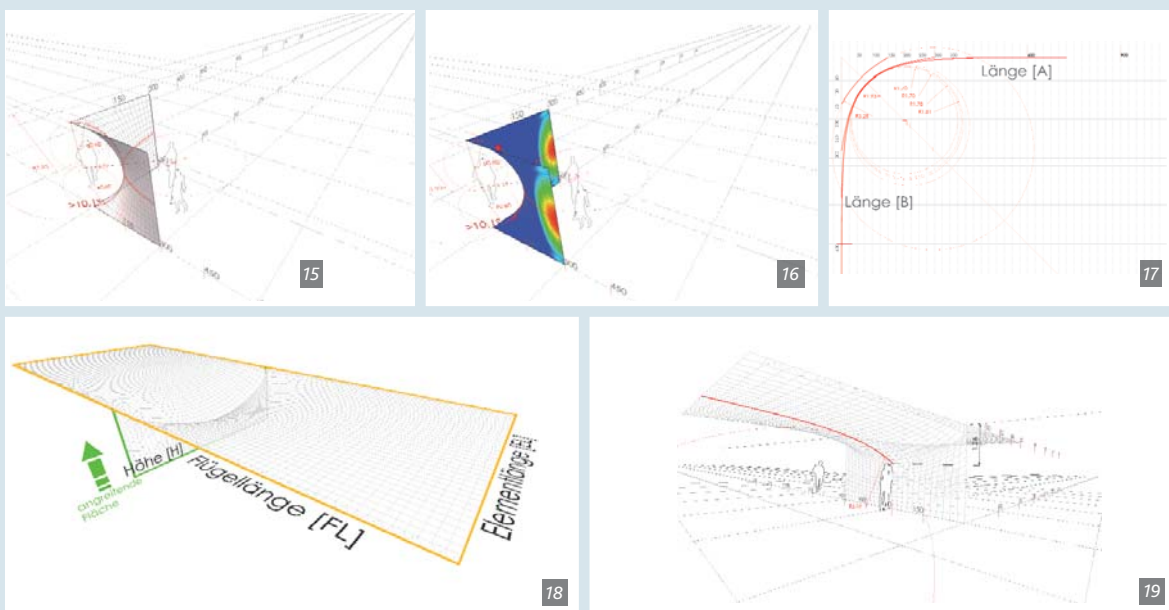

Figure 15. Horizontal corner with ratio of 1/1 (leg/leg/height)  
Figure 16. Horizontal corner with ratio of 1/1 Gaussian Curvature

Figure 17. Horizontal section lines „Horizontal Membrane Corner“ – in comparison  
Figure 18. Geometry of right angled T-connection

Figure 19. Minimal Surface generated from a right angled T-connection



Figure 20. Displacement of vertical section lines from right angled T-connection with symmetric wing length and different element length [EL]

Figure 21. T-connection with square boundary geometry  $FL = EL/2$

Figure 22. Linear increase of displacement at increasing element length up to  $EL/2 = FL$ , then nonlinear

Figure 23. T-connections different from  $90^\circ$

Figure 24. T-connection with an angle of  $60^\circ$

Figure 25. Vertical section lines  $T30^\circ, T45^\circ, T60^\circ, T75^\circ$

Figure 26. Spatially curved intersection line for  $T60^\circ$

This happens independently from the angle of the boundary connection. The 3 different parts of the Minimal Surface meet with  $120^\circ$  and form an arch-like intersection. This arch is less curved at its angular point and more curved the closer it is to the T-connection of the boundary. „In very special cases only, a circular intersection can be formed.”<sup>[2]</sup> These special cases were used to form pressure resistant arches for real structures.

#### Right-angled T-connection

In terms of right-angled configurations the leg length of H (0) has no influence on the form of the generated Minimal Surface as long as it is longer than the deflection of the Y-intersection. This happens to be the same, independently from the wings being arranged symmetrically or asymmetrically.

> Symmetric wing length [FL]: For symmetric wing length [FL] one can determine that the magnitude of the Y-intersection is directly connected to the ratio of wing length and element length. For all boundary conditions with  $FL \geq EL/2$  the magnitude of the Y-intersection equals 20,6% of the element length. For wing length shorter than the element length, a nonlinear behavior of the Y-intersection can be determined. So the boundary condition  $FL = EL/2$  represents the borderline between linear and nonlinear development of displacement in the direction of H (Fig. 20). A square geometry in plan causes evenly distributed curvature in the surface (Fig. 21).

The curved Y-intersection is similar to a basket arch (Fig. 22). Starting from a square geometry in plan increased wing length results in the generation of insufficiently curved areas at the ends of the wings. On the other hand there are no effects on the form, radii of curvature of the Minimal Surface and the transitional zone with anticlastic curvature to insufficiently curved areas does not move. The enlargement of the element length which corresponds proportionally to a reduction of the wing length causes insufficiently curved areas which are merged

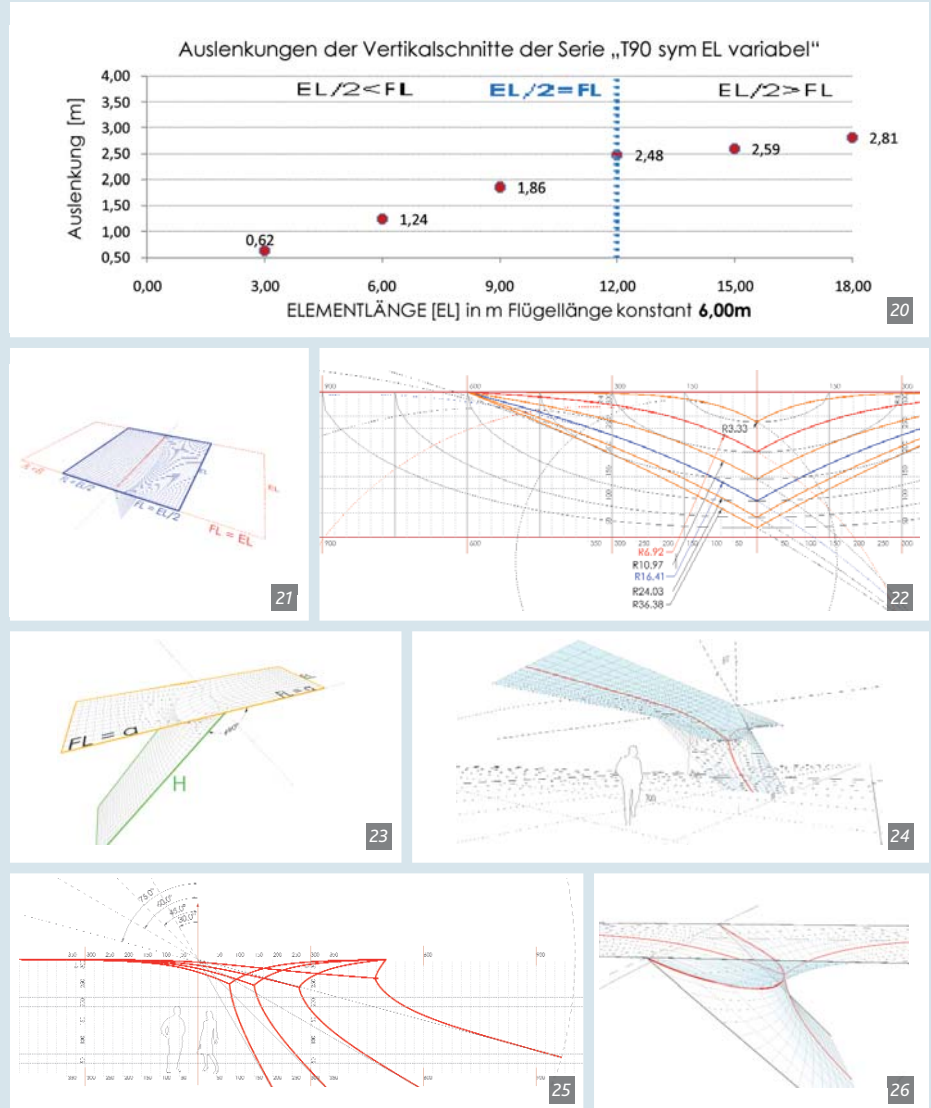

together in the element middle. Strong anticlastic curvature is limited to the areas of the T-connection of the boundary.

> Asymmetric wing length [FL]: Spatially curved Y-intersections and spatially curvature of all partial areas are generated by asymmetric wing length. The horizontal component of the deflection always occurs in direction of the larger wing.

#### Non-right-angled T-connections

When using T-connected boundaries with angles different from  $90^\circ$  the surface of H (Fig. 23), which is totally flat for the  $90^\circ$  case, will be spatially curved too. Increasing deviation of  $90^\circ$  goes along with increasing anticlastic curvature of surface H (Fig. 24). The formally interesting Minimal Surfaces which develop as a result of a T-connection with a not at right angles deviating surface H show spatially curved intersection lines. The more the angle differs from  $90^\circ$  the more the anticlastic curvature of H increases. At the same time the vertical deflection of the former horizontal parts decreases.

#### 5 Catenoid

The shape of the catenoid is basically generated by a catenary that rotates around a longitudinal axis. It is the only rotational body that can be minimal surface at the same time. As we know from SFB230 the maximum attainable height of a catenoid spanning two circular rings is approximately 1,3 times the radius of a ring.<sup>[3]</sup> For conceptual designs in architecture, boundaries different from two identical circles but with different diameters, not being arranged in one axis and/or not being symmetrically arranged are needed. So the maximum attainable heights of catenoids with different boundary geometries and arrangements were examined. New rules could be found for major boundary configurations<sup>[4]</sup>. The resulting diagrams can be scaled at will.

#### Catanoids between circular rings of different diameters

Starting from the extreme of 1,3 times the radius of a ring the maximum height of a

catenoid is decreasing if one of the rings diameter is decreasing (Fig. 27). Fig. 27 also illustrates that upper rings smaller than 1/5 (upper ring /lower ring) effect very little maximum attainable height and surfaces with little Gaussian Curvature at the same time. Several experiments showed that all the attainable maxima in dependence from the given diameters are located on a common circle - the extreme value circle. This circle again is in direct proportion to the circular base ring (Fig. 28). The developed diagram allows a determination of the maximal attainable height when the diameters of the two rings are given. The other way round the maximal diameter of the upper ring can be found by predefining the desired height and the diameter of the base ring (Fig. 29).

Case-Study A (Fig. 30)

A catenoid is perforating several floors and creates a courtyard situation. Its position is chosen the way that the ground floor gets a spatial incision whilst the other floors are still connected by a catwalk between catenoid and facade.

Case-Study G (Fig. 31)

The form of the catenoid is intersected with a rectangular building. In this case the catenoid was tilted in the direction from (left) and towards (right) the building. For this reason the opening in the façade opens on top and narrows to the sky inside the courtyard (left) and vice versa (right).

Catenoids between shifted circular rings

A displacement of the boundary rings effects lower maximum heights of catenoids (Fig. 32).

This correlation also follows precise rules. The interrelation of displacement of boundary rings and maximal attainable height of the catenoid can be found on circular movements defined by the center of the base ring and the diameter of the rings (Fig. 33).

At the same time we can observe that a displacement of more than 3/4 of the diameter of the rings effects areas with little Gaussian Curvature. Strongly curved areas can always be found at half height of the catenoid. A displacement of 1 diameter

of the boundary rings cannot be attained with a catenoid but forms two separated surfaces within the rings.

Case-Study K (Fig. 34)

A horizontal displacement of one of the boundaries of the catenoid enables a spatial movement. For the fact that the base rings of displaced catenoids have equal diameter they can act like swivel plates. This way vertical connections or orientation to natural light can be solved.

Catenoids between square rings of the same side length

Compared to catenoids generated by two circular rings, catenoids between two equal square rings (Fig. 35) are having their maximum height at 1,44times of the side length of the square (Fig. 36). In analogy to catenoids between circular rings the maximal attainable height or the smallest possible upper square can be found on a common extreme value circle too.

Catenoids between a square and a circular ring

Catenoids between a square and a circular ring don't follow an extreme value circle but

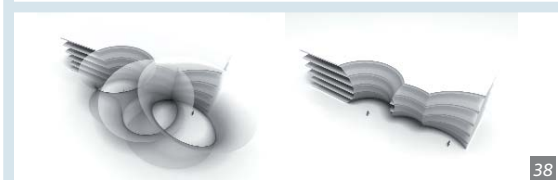
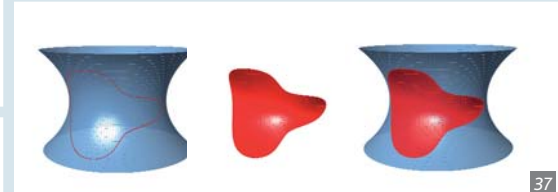
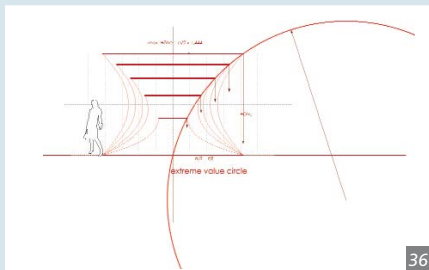
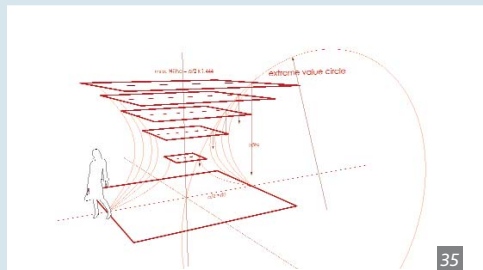
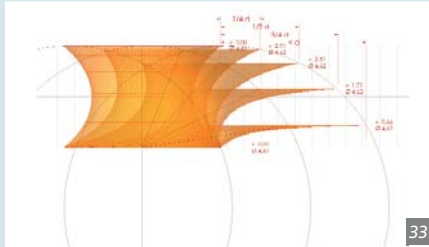
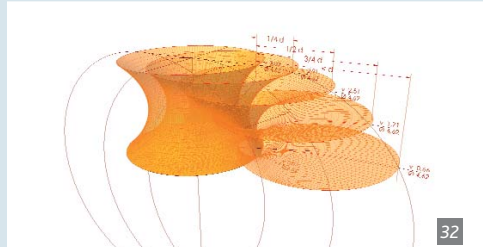
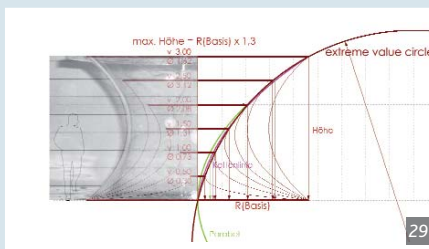
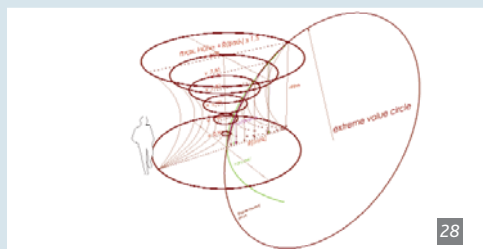
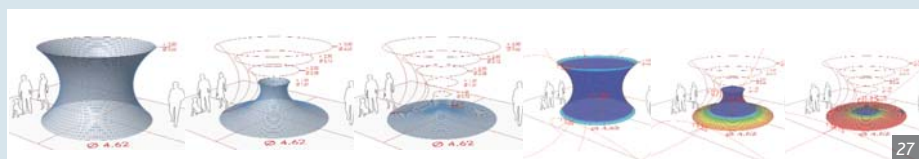



a catenarylike line starting from the center of the square and going through the quadrant of the upper circular boundary. The maximal attainable height equals 1,39times the radius of the inscribed circle of the square respectively half of its side length. This is valid for configurations where the circle is the incircle at the most.

**Congruent cut-outs from Minimal Surfaces of Catenoids**

All executed investigations have shown that each randomly selected cut-out from a Minimal Surface of a catenoid will be a Minimal Surface with equal position in space and equal curvature of the surface itself. This can be explained by the absolute identical stresses in all directions of Minimal Surfaces. The example in Fig. 37 is showing a randomly selected closed curve that is projected on the surface of a catenoid. For this reason this curve is exactly matching the surface of the initial catenoid. By defining this curve as a new boundary line the new surface within this boundary is also matching the surface of the initial catenoid.

**Case-Study M2 (Fig. 38)**

The intersection of several catenoids is possible without changing of form of the different parts. This way 3dimensionally curved ridges are developed by the intersection line. The definition of the new boundary can be found as described before, but it can also be found by intersecting different independent catenoids or by intersection with other forms. As shown in case-study M2 (Fig. 38) catenoids even don't need to have the same position in space or the same size. This way a lot of possibilities are open for a potential design in architecture.

**Conclusion on research, case-studies and experimental structures**

The characteristics that Minimal Surfaces can be proportional scaled and that a predefined cut-out of minimal surface keeps unchanged multiplies the possibilities for the design. Using the found rules case studies give an idea of the infinite possibilities that are open to create very special „soft spaces“, with new architectural qualities like shown in above case studies and experimental structures (Fig. 39 to Fig. 41) and furthermore.

**Perspective**

Latest approaches are dealing with alternative boundary-conditions and with software implementation in terms of scripting found rules<sup>[5]</sup> (Fig. 42). The aspect of geometrical regularity a visual irregularity of anticlastic Minimal Surfaces is subject of an actual research project. An investigation on the correlation of self organizing forms, their close relation to nature and their aesthetic values also seems to be interesting questions for the future.

*Günther H. FILZ*  
 guenther.filz@uibk.ac.at  
 www.koge.at

REFERENCES

- [1] Filz, Günther, "DAS WEICHE HAUS soft.spaces", Dissertation, Leopold-Franzens-Universität Innsbruck, Fakultät für Architektur, Juli 2010
- [2] Otto, Frei, IL 18, Seifenblasen, Karl Krämer Verlag, Stuttgart 1988
- [3] Mitteilungen des SFB230, Heft7, Sonderforschungsbereich 230, "Natürliche Konstruktionen – Leichtbau in Architektur und Natur", Universität Stuttgart, Universität Tübingen, Sprint Druck GmbH, Stuttgart 199
- [4] Filz, Günther, "minimal is maximal soft.spaces", accepted for Paper Proceedings, IABSE-IASS Symposium London 2011 "Taller, Longer, Lighter", London, 20-23 September 2011
- [5] Filz, Günther ; Maleczek, Rupert; "From Basic Research to Scripting in Architecture", Workshop at "2nd International Conference on Architecture and Structure" and "3rd National Conference on Spatial Structures", Centre of Excellence in Architectural Technology of the University of Tehran, Iran, 15-18 June 2011.

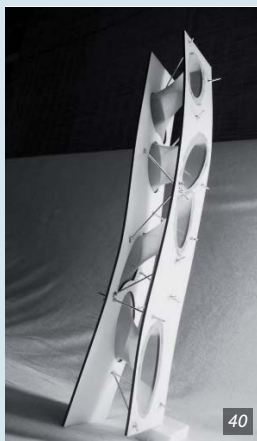
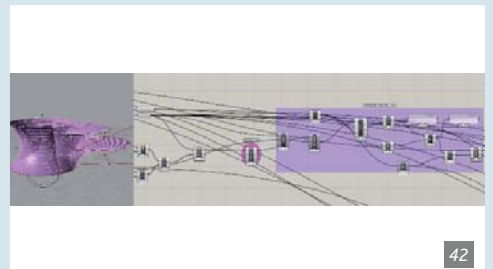
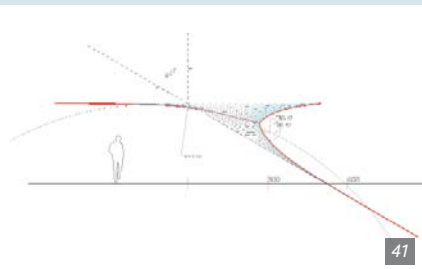
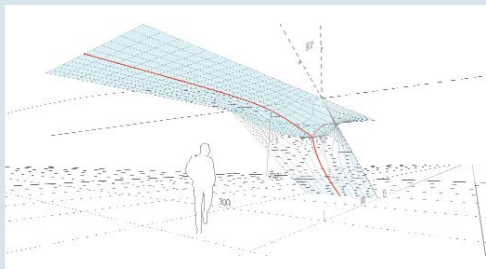

Figure 27. Change of form and change of Gaussian Curvature of a Catenoid with decreasing diameter of upper ring and therefore decreasing height

Figure 28. 3dimensional diagram for catenoids between circular rings of different diameters

Figure 29. Soapfilm model and diagram for catenoids between circular rings of different diameters

Figure 30. Case-Study A

Figure 31. Case-Study G

Figure 32. 3d view of overlaid catenoids between shifted circular rings showing the circular movement of the upper ring and the dependence of horizontal displacement of the rings and the loss of height.

Figure 33. Side view of overlaid catenoids between shifted circular rings showing the circular movement of the upper ring and the dependence of horizontal displacement of the rings and the loss of height

Figure 34. Case-study K

Figure 35. 3dimensional diagram for catenoids between square rings of the same side length

Figure 36. Diagram for catenoids between square rings of the same side length

Figure 37. Congruent cut-outs from Minimal Surfaces of Catenoids

Figure 38. Case Study M2

Figure 39. "Cube of Clouds" experimental structure in model and in scale 1/1 by koge, Institute of Structure and Design,

head E. Schaur, University of Innsbruck, exhibited and published at Premierentage 2005, Best of 2005 and Ziviltechnikertagung 2005

Figure 40. "Cut.enoid.tower" - experimental structure with a height of about 13m in scale 1/1. The distorted appearance is generated by the interaction of pin-joint columns, which work on compression only and different versions of prestressed catenoids.

Figure 41. "minimal T" - structure shows the possibility to deflect surfaces that were flat before being assembled by using special geometries in arrangement

Figure 42. Grasshopper script "Catenoids between horizontally shifted circular rings"

Context

LAVA's Home of the Future is a showcase for future living, with nature, technology and man in a new harmony. The Home of the Future will start construction in late 2011 on the rooftop of a new furniture mall in Beijing, China (Fig.1).



Figure 1. Visualization Future Living day and night. © Doug and Wolf

Project

An ETFE geodesic skydome provides a year-round microclimate that opens up the home to a garden filled with sun, light and fresh air, away from the pollution and noise of the city (Fig. 2). Visitors will experience fifteen different living spaces, from internal/external bathroom zones to kitchens flowing to veggie patches and barbeques to sunken bedrooms with dream inducing lighting. At night the home and the tropical garden turn into an otherworldly experience, with the underlying technology, the electronic veins of the system, coming to life. The design is inspired by nature's efficiencies – corals, cells and bubbles - and creates an environment where technologies are invisibly integrated to satisfy everyday needs and senses. Its fluid design

and organisational strategy based on cells is easily modified to suit specific requirements. The Home of the Future integrates the latest improvements in comfort and instantaneous information technology with a space that embraces nature.

# Home of the Future

## A SHOWCASE FOR FUTURE LIVING

### Beijing, China

Chris Bosse, Director of LAVA says: 'The Home of the Future acts as a metaphor for the questions of our times, our relationship with nature, with technology and with ourselves'. LAVA's Home of the Future is a showcase for future living - it balances man's needs with nature and technology in perfect harmony.

Team LAVA: Chris Bosse, Tobias Wallisser, Alexander Rieck  
Landscape: Aecom  
Engineering support: Arup  
ETFE: Vector Foiltec

Jane Silversmith  
jane\_silversmith@mac.com  
www.l-a-v-a.net

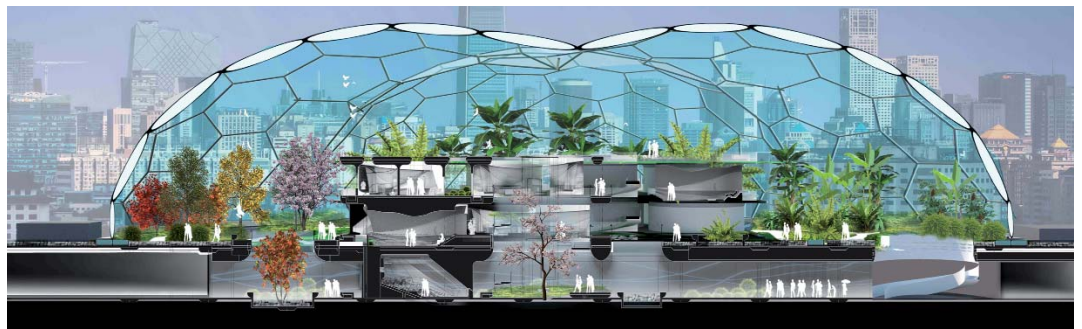

Figure 2. Section through the ETFE geodesic skydome. © Doug and Wolf

## A COMPLETED ROOF MADE OF 30.000M<sup>2</sup> HIGH-LIGHT TRANSMISSION MEMBRANES

SAINT-GOBAIN BIRDAIR

# La Plata Stadium

## Argentina

Context

More than 10 years ago, over 30.000m<sup>2</sup> of ULTRALUX® I Architectural Membrane was manufactured to top a new stadium in La Plata, Argentina. For various reasons, the stadium was built but the roof was never installed until last year. The roof features a unique style, a double cable dome which provides a figure eight shape, was added to complete this beautiful stadium. Today, the stadium is completed and looks amazing (Fig. 1).

Membrane

For the membrane the high translucency architectural membrane ULTRALUX was chosen. ULTRALUX is made of fiberglass and polytetrafluoroethylene (PTFE) and provides about 25% light transmission as opposed to standard products which provide 10 to 16% light transmission. ULTRALUX is manufactured by Saint-Gobain in the Merrimack, NH plant.

Cable structure

Birdair engineered, fabricated and oversaw the installation of the cable structure and fabric roof. Birdair's steel cable systems was used. To accommodate the unconventional geometry of the stadium, the main roof structure was formed using tensioned steel cable hoops at three different levels, along with vertical columns, diagonal cables, and ridge cables. This prestressed tensegrity design features a figure-eight-shaped central opening that resists global distortion using tension. Consequently, the roof deck is extremely stiff, similar to the way a drum skin is stiffened by tensioning.



Figure 1. Aerial view of the completed roof  
Figure 2. Installation of the cable structure © Birdair  
Figure 3. Inside view of the completed roof © Birdair

Roland Keil  
roland.keil@saint-gobain.com  
Saint-Gobain performance Plastics  
www.chemfab.com - www.sheerfill.com - www.birdair.com

Name of the project:	La Plata Stadium
Function of building:	sport and cultural events
Year of construction:	2011
Architects:	Roberto Ferreira
Engineer:	Weidlinger and Associates, New York, New York
General contractor:	Astillero Rio Santiago, Rio Santiago, Ensenada, Argentina
Supplier of the membrane material:	Saint-Gobain
Material:	ULTRALUX® I Architectural Membrane
Covered surface (roofed area):	30.000m <sup>2</sup>



# Membrane roof

## Rhein-Galerie in Ludwigshafen, Germany



### Introduction

The Rhein-Galerie, located directly on the bank of the river Rhine in Ludwigshafen, provides an attractive place to shop and have fun. Around 130 specialist retailers provide a modern variety of products and services over 30.000m<sup>2</sup> of sales space spread out over two floors. The adjacent Rheinpromenade directly connects the Rhein-Galerie with the Rhine.

### Imposing roof architecture

Particularly memorable is the membrane roof designed to create an architectural link between the river and the rhythmic oscillations of the building's lateral arches. The translucent roof covers the entire shopping centre and lends the architecture a distinctive character.

### High-quality materials

for optimum interior conditions The decision was taken to use PTFE (Teflon®) coated glass fabric. This material's long life is not its only impressive trait. The Teflon® surface coating also makes it easy to clean, because ordinary dirt and dust is simply washed away by rain. The high level of sunlight reflected off the surface as a result of the white colour ensures that the area under the membrane roof is heated less, but also ensures that a high level of light from outside can penetrate the roof, as was desired.

### Elegant structure with unique details

The supporting structure of this extraordinary building is an elegant, three-dimensional, curved structure supported by a welded steel tube girder framework consisting of column supports upon which arches and frames were built. There are a total of 68 discrete surfaces, which are clad with mechanically pre-stressed membrane sheets. The roof surface is left open above the interlocking elliptical courtyards of the interior in order to ensure optimum lighting from outside.

The membrane sheets were fixed into place using steel fixture strips for each sheet, following the curved form of the steel structure. The membranes were joined using aluminium sections that were produced specially for this project, and these were also pre-cast. The joints between the sections were sealed by mounting them on modified extruded neoprene strip seals. The aluminium sections allow

each of the membrane sheets to be subjected to linear pre-stressing and fixed in place in a straight line without having screws penetrate the surface of the membranes.

### Produced precisely to order

One of the core tasks was to produce the 68 membrane sheets with sizes of between 70 and 380m<sup>2</sup> in the Greven factory in a way that enabled them to be fitted directly at the shopping centre without any further modifications. This advance production process used the 3D model provided by the steelworker as the basis, together with jointly agreed production tolerances. In order to ensure that the membranes were sufficiently pre-stressed, thereby providing them with sufficient long-term stability against snow and wind, the tensile properties of the coated fabric were determined using biaxial testing. This process enabled each of the sheets to be produced precisely in advance while the construction of the steel structure was ongoing.





### Planning the fitting process – down to the last detail

The panels were fitted by a team of experienced industrial climbers. Because the coated glass sheets were so susceptible to kinking, a refined and precise plan for fitting them had to be developed.

Firstly, the sheets were spread out on a pre-mounted support net and protected from exposure to the wind. They then had the special aluminium sections attached to all sides. The linear pre-stressing of around 4KN/m had to be applied in steps to ensure that the material was not damaged. It was only at the end that the aluminium section could be attached to the supporting steelwork with the sealant strips and corresponding screw joints.

The three-dimensional nature of the structure and the necessity of doubling over and reinforcing the edges meant that around 33.000m<sup>2</sup> of material were processed in order to cover around 24.000m<sup>2</sup> of surface area. The fitting took a total of eight months.

Name of the project	Membrane roof for the Rhein-Galerie in Ludwigshafen
Location address	Ludwigshafen, Germany
Client	Rhein-Galerie GmbH & Co.KG, Hamburg
Year of construction	2010
Architect	ECE Projektmanagement GmbH & Co.KG
General contractor	Ed. Züblin AG
Manufacturer	
membrane roof	Ceno Tec GmbH Textile Constructions
Material	Glass PTFE
Covered area	24.400m <sup>2</sup> – 60 facade fields and 68 roof fields

 Bosse Anne  
 Anne.Bosse@ceno-tec.de  
 www.ceno-tec.de  
 Illustrations/photos  
 ECE Projektmanagement  
 GmbH & Co.KG

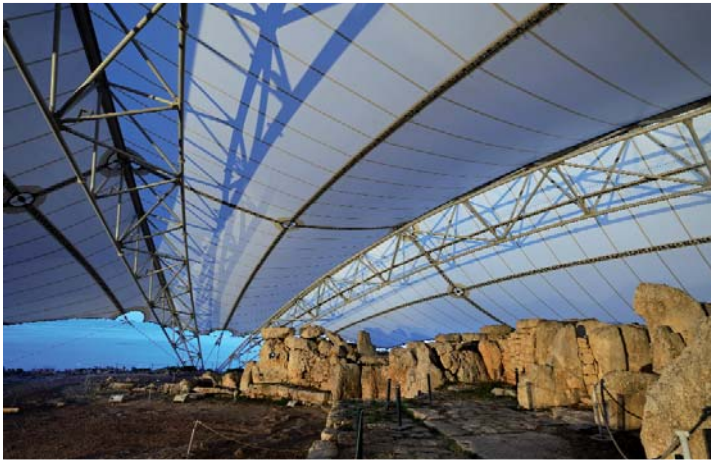

FORM TL

## MEMBRANE ROOFS SHELTER Stone-age temple

Malta

### Context

To protect the approx. 5.000 years old temple complexes Hagar Qim and Mnajdra on the island of Malta against erosion, two membrane structures have been developed, which now cover and protect the archeological excavation. For thousands of years the stony cult sites have been overwhelmed before in 1839 their unearthing was started. Hagar Qim and Mnajdra are situated at the South coast of Malta at only 500m distance. Built between 3.600 and 2.500 B.C., the sites made of lime stone blocks became UNESCO-world heritage sites in 1992. Since their excavation the rough environmental conditions have affected the temples Hagar Qim and Mnajdra strongly. The soft lime stone impeded an accelerated dilapidation by salty rain and high variations in temperature. In the year 2000 a

group of scientists suggested to build a conservation and interpretation protection according to UNESCO regulations over the cult sites. This is weather protection on the one side and the encouragement of attentive visitor's behaviour on the other side to protect the fragile temple sites from further dilapidation.

### International UNESCO competition

The design of these roofs has been part of an international UNESCO competition which was won by the Swiss architect Walter Hunziker in 2003. Supported by the engineering office KTA the original steep membrane roofs with one arch became flat roofs with two inclined arches. formTL was contracted with the final design and the structural design as well as the pattern design by the North-Italian general

contractor and membrane manufacturer Canobbio SpA.

### Project

Three important preconditions had to be taken into account: the roofs needed to be deconstructable without visible effects after the restoration of the sites in 25 or 30 years and their design had to follow the astronomical alignment of the temples. At certain times of the year the roofs should not impede the insolation at certain dates like the summer and winter solstice. And they should offer the maximum weather protection. The geometry was only partly given due to the individual topography, but could be solved similar in design: The developed structures consist of two center positioned, slightly inclined steel arches. Between the arches and to the side frames a cable net with membrane



panels is spanned. The biaxial cable nets allow to realize the arches without any additional stabilization cables.

During the design process the roof shapes have been adapted to the situation on site. Step by step the structures have been adjusted with the gradually generated dimensional geometrical survey of the temples and their surroundings until the roofs fulfill all demands perfectly.

Even the bearing points had to be changed several times because before approval they had to be checked archeologically first. Now the visitor experiences a cathedral like effect. If he steps under one of the big roofs he tones down his voice automatically and he is behaving more respectful than before. Where it was common to sit

on the temple ruins or to scratch at them, the visitor becomes a wandering observer.

The effect of the roof is very protective because the climate close to the temples had changed. The very absorbent and soft lime stone stays permanently dry now, because the salty rain brings nearly no humidity to the stones.

The PTFE coated glass fabric filters the sun light and reduces its intensity to 10 to 15%. So the lime stone walls are protected from the ultra-violet radiation, but can be looked at with natural light conditions. It is also important that the textile covering reduces the amplitudes of the stone temperature of 20°-70°-20°C considerably. Now the temperature value oscillates only in the range of the air temperature.

## Erection

Another big challenge was the protection of the excavation site during the construction period and the restrictions involved.

To protect the temples during the construction period they are neither allowed to be trespassed nor touched.

The use of big machines and a scaffolding was therefore not possible. The complete cable and

membrane structure had to be assembled piece by piece by professional climbers - and the roof panels were closed one after the other.

 **Gerd Schmid**  
 [gerd.schmid@form-tl.de](mailto:gerd.schmid@form-tl.de)  
 [www.form-TL.de](http://www.form-TL.de)  
 **Marco Ansaloni**

Name of the project:	Membrane roofs shelter stone-age temple, Malta
Client:	Heritage Malta, Malta
Architect:	Walter Hunziker Architekten AG, Bern
Preliminary structural design, tender documents:	Kiefer.Textile Architektur.
Final structural design, membrane design, workshop drawings:	formTL GmbH
General contractor:	Canobbio Spa.
Steel:	Mecoop
Cables:	Teci
Assembly:	Montageservice SL
Covered surface	1.495m <sup>2</sup> Hagar Qim/ 2.460m <sup>2</sup> Mnajdra
Span central arch	54m Hagar Qim/ 68m Mnajdra
Material Membrane:	Hagar Qim: PTFE-coated glass fabric SHEERFILL®I-HT Mnajdra: PTFE-coated glass fabric SHEERFILL®I-HT

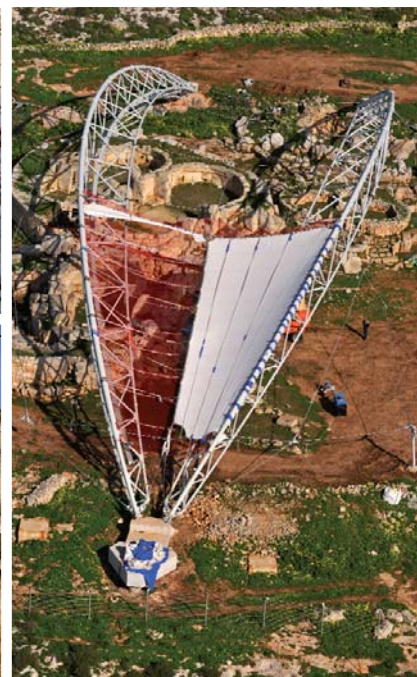

## Fibrous and composite materials for civil engineering applications



Author: R. Figueiro, University of Minho, Portugal  
 Language: English  
 Size: 400 pages 234 x 156mm (hardback)  
 Editor: Woodhead Publishing Limited (2011)  
 ISBN 1 84569 558 5  
 ISBN-13: 978 1 84569 558 3

### Content:

PART 1 Types of fibrous textiles and structures;  
 PART 2 Fibrous materials as a concrete reinforcement material;  
 PART 3 Fibrous materials based composites for civil engineering applications.

## LITERATURE

### Textiles, polymers and composites for buildings



Author: G. Pohl, Leichtbau Institut, Germany  
 Language: English  
 Size: 524 pages 234 x 156mm (hardback)  
 Editor: Woodhead Publishing Limited (2010)  
 ISBN 1 84569 397 3  
 ISBN-13: 978 1 84569 397 8

### Content:

PART 1 Main types of textiles and polymers used in building and construction;  
 PART 2 Applications of textiles and polymers in construction.



4<sup>th</sup> Latin American Symposium Uruguay

## Tensile Structures Montevideo 2011

The "4<sup>th</sup> Latin American Symposium of Tensile Structures" was held in Montevideo in April 2011. It was organized by the Faculty of Architecture of the University of the Republic, Uruguay, and chaired by the architect R. Santomauro. It was the fourth in a series of symposiums that began in São Paulo in 2002, followed by Caracas in 2005 and Mexico D.F. in 2008.

Over three days, 11 lectures and 31 presentations were given to 278 participants from 19 countries and three continents.

The main topics focused on recent projects, as well as new applications, basic concepts, features, materials, design, software, testing, installation and education.



### Main Lectures

Following the welcome address by the Dean of the Faculty and the introduction to the Symposium by R. Santomauro, N. Goldsmith presented "Skin. Biomembranes in buildings".

After discussing natural skins, he went on to talk about building skins as holistic solutions in which the body and skin perform together, integrating structure and environmental design concepts. He used a series of case studies on the work of FTL Design Engineering Studio (Future Tents LTD) to discuss several applications related to structure, form, acoustics, shading, lighting surface, energy generation, insulation and water collection that transform the notion of building facades into a porous multifunctional membrane reflecting the natural world. Special emphasis was placed on two textile roofs: the Sun Valley Pavilion (Fig. 1) for its dialogue between fabric and stone, and the Skysong at ASU Campus, Scottsdale, AZ (Fig. 2) for its dynamic rotational symmetry.

G. Schmid reminded the audience of the advantages of "ETFE" compared with glass in terms of

cost and maintenance based on transparency, spectral transmission, lightweight, stiffness, vapour barrier behaviour and thermal coefficients. He also referred to the particularities of cutting patterning, production and assembly and emphasized the printing, colouring, lighting and self-cleaning capabilities together with recent applications in many fields that allow forward-looking architects to design their self-marketing envelopes (Fig. 3).

The most frequently mentioned realization, with two main lectures and two presentations, was "La Plata Stadium" in Argentina (G. Castro, R. Ferreira, F. García Zúñiga, H. Larrotonda, M. Levy and T. Birdair), a derivative of the tensegrity Georgia Dome. Several speakers outlined the construction engineering, planning and procedures for the roof assembly, detailing the cable net lifting, jacking system and membrane installation (Fig. 4).

In "Ejemplos en y desde Uruguay. Metodología de trabajo", P. Pinto and R. Santomauro presented the Uruguayan state of the art with a wealth of examples and a detailed description of the entire process, from a simple primary

idea to the exact definition of the project, including all of the structural elements and their details, the membrane, its patterns and its installation on site (Fig. 5).

In "Lightweight structures and membranes for stadiums", K. Stockhusen from SBP insisted on the design and installation of roofs for large-span applications. Worldwide developments in recent decades culminate in the designs of the sports venues for the World Cup 2010 in South Africa and the future icons of the Brazilian World Cup in 2014. Other impressive realizations were presented from the Berlin Olympic Stadium 2010 to the Warsaw National Stadium 2012 and Rio de Janeiro Maracana Stadium 2014 (Fig. 6).

C. Bauer from Mehler Tex•nologies began his presentation "Tensile architecture. Principles of feasibility, sustainability and reliability in the practice" with the Vitruvius principles (durability, utility and beauty) and summarized a chronological development and possible future evolutions. He described several aspects of tensile architecture as advantageous and



- Figure 1. Sun Valley Pavilion, Idaho, USA
- Figure 2. Skysong, ASU Campus, Scottsdale, AZ, USA
- Figure 3. Unilever façade, Germany
- Figure 4. La Plata Stadium, Argentina
- Figure 5. Plaza Synergia, Zonamérica, Montevideo, Uruguay
- Figure 6. National Stadium, Warsaw, Poland
- Figure 7. Harbin Sports Stadium, China
- Figure 8. London Olympic Stadium lighting tower, UK
- Figure 9. Archetto. Espositore di vendita all'aperto, Napoli, Italy
- Figure 10. Landfilling, incinerating or recycling?
- Figure 11. Estadio Municipal Lucio Fernandez Fariña, Quillota, Chile

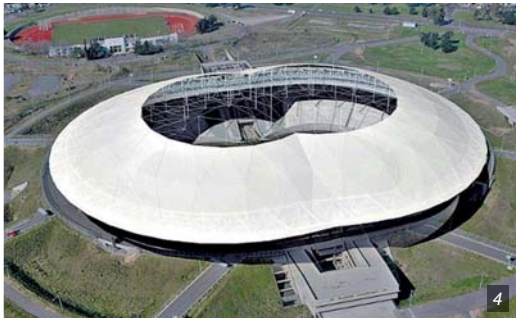

A. Capasso presented **"Membrane architecture: from research to teaching and realizations 40 years between the sails"**, based on the research, teaching activities and realizations of light structures that the author has carried out at the University of Naples' Faculty of Architecture. Highlights of his career include the sails of the Triennale di Milano in 1973; Le tensostruttura a membrana per l'architettura, the first handbook on membrane structures in Europe in 1993; the international conference *"Architettura e leggerezza"*; and the *Laboratorio di Tecnologie leggere per l'ambiente costruito* at the University of Naples, established in 2000. His current work involves university theses and research into developing various functional and environmental possibilities for textile technology (Fig. 9).

J. Llorens lectured on **"Detailing tensile structures"**, which form a substantial part of the design process and influence the final result, but do not yet form a well-known and well-documented discipline. He presented a design methodology for detailing tensile structures based on the principles governing their behaviour and a prior recognition of the requirements to be met, taking into account the characteristics of the project to which they belong. A typology was also illustrated by specific examples placed in context that are available at <http://sites.upc.es/~www-ca1/cat/recerca/tensilestruc/portada.html>.

S. Delano and T. Dreyfus (Ferrari) in **"Sustainable development strategy in textile composites"** went into the material properties that are specially suited for permanent installations, such as lightness, translucency and longevity. They furnished data on weight/m<sup>2</sup>, residual tensile strength (80% to 100%), exposition to severe climatic conditions, energy savings by protecting façades (more than 60% under the Latin American climate!), cost of recycling (~450 €/T) and life cycle analysis (Fig. 10).

In **"Tensoestructuras. Diseños peruanos para el mundo"**, A. Pérez and G. Carella presented a wide variety of textile roofs designed or built by Cidelsa, a Peruvian company that specializes



in architectural design and engineering, membrane transformation, high-frequency welding, manufacturing of steel structures and accessories, and assembly. The collection of projects included shopping centres, stadiums, museums, convention centres, beer gardens, squares, sports halls and stations (Fig. 11).

### Current research

G. Filz from the Institute for Structure and Design (University of Innsbruck) presented in **"Soft Spaces"** his current research on anticlastic minimal surfaces that considers the infinite possibilities of membrane forms as new elements in architecture in combination with common building technologies that deliver new capabilities in designing and creating space.

**"Climatic Criteria for the Design of Tensile-Structures in Regions of the Humid Tropics"** by J.F. Flor dealt with the passive adaptation to the climatic conditions of the humid tropic to obtain architectonic spaces that reach the maximum hydrothermal comfort of users with the minimum resources.

In **"Adaptable Structures"**, R. Franco explored more than 20 mobile systems, aiming to apply the features of these systems to build and develop an adaptable architecture that satisfies the needs of the contemporary world.

P. von Krüger (Universidade Federal de Minas Gerais) returned to the **application of the tensegrity principles** to latticed domes with associated membranes as an active cover that stretches the structure.

C. Morales (Universidad Veracruzana) based his **"Design of Structural Flexible Systems in the Architectural Space"** on the understanding of organic forms to construct a design methodology aimed at flexibility.

L. Moreira (Universidade Federal de Minas Gerais), explored in **"Form Finding of Tensile Structures Made of Bamboo"** the integration of physical and mathematical models.

Numerical methods were also present in **"New Strategies in Form Finding for Tensile Structures"** by F. Pantano (Uni Systems) and **"The Natural Force Density Method for the Shape Finding of Membrane Structures"** by R.M. Pauletti (Universidade de São Paulo).

mentioned large spans, light conditions, economy (of time, energy and materials), efficiency, eye-catching forms, versatility, fire performance, uniqueness and cost (Fig. 7). A special reference was made to sustainability, recycling systems and the need to rely on the right consultancy, specialist industry and practical support. The Mehler TensileDraw available at [www.mehler-texnologies.com](http://www.mehler-texnologies.com) was recommended.

F. McCormick (Buro Happold) displayed in some detail the installation of the environmentally friendly 22.000m<sup>2</sup> roof for the 80.000 seat **"2012 London Olympic Stadium"**. To provide more potential for world records, complex CFD was used to analyse the wind regime on the track and field, which revealed that a roof covering will attenuate wind speeds. In addition, the 28m high lighting towers were lifted on top of the inner ring in order to avoid disturbing photographers. These are new requirements for contemporary stadiums that have to be added to the FIFA demands for visibility of the advertising strip around the field and may invalidate most contemporary designs (Fig. 8).

### Comparative multi-criteria analyses - Example for Batylina

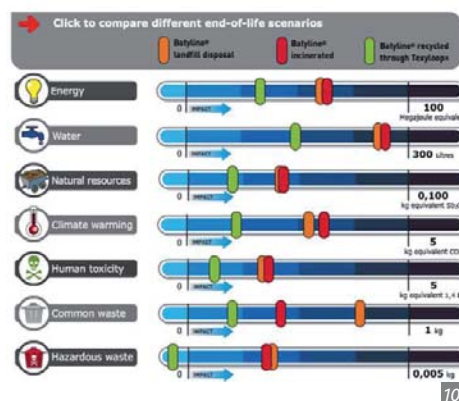

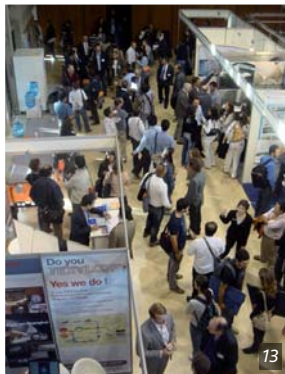

Figure 12. Software demonstration  
Figure 13. Symposium exhibition  
Figure 14. Tensowrap"  
Winner of the student competition

## Testing Methods

In "Structural behaviour of textile roofs under different climatic conditions", C. Hernández (Instituto de Desarrollo Experimental de la Construcción) showed the design of a testing apparatus and procedure for measuring the influence of humidity, temperature and wind on the pretension of hypars.

J. Blessman (Laboratório de Aerodinâmica das Construções, Rio Grande do Sul) was in charge of the last presentation of the Symposium, which dealt with **wind tunnel testing techniques**.

## Other presentations

Several Latin American countries were represented and the latest realizations in Argentina (W. Runza and P.C. Valenzuela), Brazil (P.A. Barroso), Chile (O. Sotomayor) and México (J.G. Oliva, M. Ontiveros, V.H. Roldán and E. Valdez) were shown.

J. Monjo, representing H. Bögner-Balz for TensiNet, summarised the aims, objectives and activities of the Association, which was particularly relevant because the Latin American Network meeting was held afterwards.

## Education

Several proposals and experiences for education were presented by leading professors from Latin American institutions.

- J.G. Oliva Salinas: "**Curso de Arquitectura Textil**", 17 to 21 October 2011 plus 2 months online, Universidad Nacional Autónoma de México. His experience was discussed by P. Villanueva in the presentation "Contemporary teaching of tension structures", in which the online form finding of membrane structures "Membranes 24" is used (<http://www.membranes24.com>)
- J. Monjo: "**Curso de Arquitectura Textil**" 2011/2012 (15 + 30 + 60 ECTS), Universidad Politécnica de Madrid. He discussed his experience in the presentation "Teaching Tensile Structures".

- Robert Wehdorn: "**Membrane Lightweight Structures**", Master Engineering Program (90 ECTS), Vienna University of Technology (<http://mls.tuwien.ac.at>).
- Unfortunately, Robert Off didn't attend the Symposium to present his "**Archineer and Master of Engineering in Membrane Structures**", Anhalt University of Applied Sciences, Dessau (<http://www.membranestructures.de>).

## Software demonstrations (Fig. 12)

In sessions parallel to the lectures and presentations, demonstrations of specific software for designing tensile surface structures were led by: Gerry d'Anza "ixForten 4000" ([www.forten32.com](http://www.forten32.com)); Dieter Ströbel "technet GmbH" ([www.technet-gmbh.com](http://www.technet-gmbh.com)) and Robert Wehdorn "Formfinder" ([www.formfinder.at](http://www.formfinder.at))

## Exhibitors (Fig. 13)

The exhibition of products in the main hall of the Faculty included Cidelsa ([www.cidelsa.com](http://www.cidelsa.com)), Ferrari ([www.ferrari-architecture.com](http://www.ferrari-architecture.com)), ixForTen 4000 ([www.forten32.com](http://www.forten32.com)), Formfinder ([www.formfinder.at](http://www.formfinder.at)), Makmax Birdair Taiyo Kogyo ([www.makmax.com](http://www.makmax.com)), Mehler ([www.mehler-technologies.com](http://www.mehler-technologies.com)), Naizil SpA ([www.naizil.com](http://www.naizil.com)), Sobresaliente ([www.sobresaliente.com](http://www.sobresaliente.com)), Synthesis-Gale Pacific ([www.synthesisfabrics.com](http://www.synthesisfabrics.com)), Verseidag ([www.verseidag.de](http://www.verseidag.de)) and Wagg ([www.wakk.com.ar](http://www.wakk.com.ar)).

## Student competition

The competition for design projects that make use of textile, cable or tensegrity structures, which was open to architecture and engineering students, received 10 proposals. The jury, composed of J. Monjo, N. Goldsmith and G. D'Anza, awarded R. Vivar and J. Tataje for "Tensowrap: signals – protection – security" (Fig. 14).

## Other activities

T. Birdair offered the Welcome Cocktail, during which music was provided by a sax quartet. The "criolla" Symposium dinner was the opportunity to enjoy a Uruguayan meal. The city of Montevideo was also worth visiting, particularly the double-curved thin-walled shell in single-thickness reinforced bricks by Eladio Dieste (Fig. 15).





Figure 15. Eladio Dieste Chapel

## Latin American Network of Tensile Structures

The 4th Symposium was also the occasion to meet the Latin American Network of Tensile Structures. It assembled 60 participants with an interest in regional activities and envisaged the collaboration or association with TensiNet. They decided to hold the next Latin American Symposiums in Santiago de Chile in 2012 and in São Paulo in 2014.

## Conclusion

The Symposium ended with a panel discussion on tensile structures in Latin American countries, during which we learnt that Latin American countries are not only fully involved in the development of tensile structures, but that they will also be very active in the coming years and constitute a key scenario for the future.

 Josep I. de Llorens  
 [ignasi.llorens@upc.edu](mailto:ignasi.llorens@upc.edu)  
 [www.tens-mvd2011.org](http://www.tens-mvd2011.org)



# TEXTILE WRAP

## A SUSTAINABLE CONSTRUCTION

Ecopolis Plaza,  
Madrid, Spain

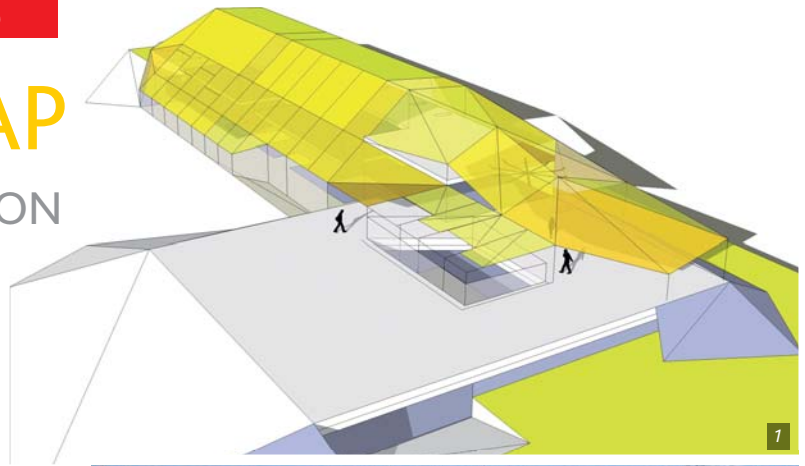

### Context

Transformation of a faceless site in Madrid's urban sprawl, surrounded by industry and heavy traffic transportation infrastructures, into a public space for social interaction providing a building for childcare (Fig. 1).

### Project

The project "Plaza Ecopolis" aims to incorporate the idea of sustainability into daily life. The main focus is therefore to create a vision of urban sustainability that facilitates the reduction of energy consumption by matters of design but that also aims at raising people's awareness of their own consumption behaviour. The layout of the building generates a public space that can be used by the area's residents, and it is considered as an "open environmental classroom".

Technologies implemented at Ecopolis project are helping the initial bioclimatic design approach based on minimizing the consumption of both energy and natural resources. The Ecopolis Plaza project has the highest eco-label (A grade) of Spanish law. A complete energy simulation study developed by the Thermodynamics Research Group at the Industrial Engineering School of Seville, helps to understand the behaviour of the building and also to adjust the available construction budget. An important area of the building half-buried (50% of the building takes advantage of the land's thermal inertia) and a large glass facade facing south (700m<sup>2</sup>) are basic decisions that shape the physical relationship between the building and its environment. A bioclimatic textile layer superimposed over a light steel structure is wrapping the rational concrete core of the building. This textile (partially movable, connected with sensors to sun position) is the interface between interior and exterior spaces, blurring the boundaries between private and public and extending the inner comfort to the public space (Fig. 2).



Figure 1. Aerial view of the Ecopolis Plaza

The textile envelope is made of two kind of PES/PVC meshes: Ferrari Soltis 86 and 92 in order to help view and solar control, and the final amount of energy coming inside the building (Fig. 3). The zeroelastic surfaces drain rainfall due to the mesh porosity, but needed to be designed with high prestress loads in order to prevent damages due to snow and wind loads. The building extends its limits into the plaza and part of its functional processes are placed outside to make them more transparent to the public, creating a more conscious way of wasting natural resources. The sewage system ends into a lagoon in front of the building where all the waste water from the building is naturally purified by macrophyte plants. All the purified water is stored under the ground within a gravel tank and it is used for all the irrigation needs of the plaza, this artificial landscape emulates a natural riverbank.

Ecopolis Plaza is also a demonstrative experience of economy of means applied to the field of sustainable construction, where efficiency usually means higher construction cost. The Ecopolis project cost per square meter is more than 35% less than a conventional building.

-  Javier Tejera, José Javier Bataller, Marian Marco
-  tejera@batspain.com
-  www.batspain.com
-  José Luis Vallejo, Belinda Tato
-  www.ecosistemaurbano.com

### Additional information:

<http://inhabitat.com/madrids-sustainable-ecopolis-plaza-is-a-versatile-public-space/>

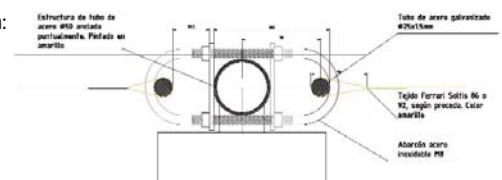

Figure 3. Connection detail

Name of the project:	Ecopolis Plaza
Location address:	Rivas Vaciamadrid, Madrid
Client:	Rivas Council
Function of building:	Educational
Type of application of the membrane:	Textile Roof And Facade
Year of construction:	2011
Architects:	Ecosistemaurbano, José Luis Vallejo, Belinda Tato
Textile Engineering:	Javier Tejera, José Javier Bataller, Marian Marco - Bat Spain
Main contractor:	HM
Contractor for the membrane (Tensile membrane contractor):	Bat Spain
Supplier of the membrane material:	Ferrari
Manufacture and installation:	Bat Spain
Covered surface (roofed area):	1500m <sup>2</sup>



Figure 2. Textile as the interface between interior and exterior spaces



# INTERNATIONAL "TEXTILE STRUCTURE FOR NEW BUILDING 2011" COMPETITION FOR STUDENTS AT TECHTEXTIL



The international student competition „Textile Structures for New Building“ was held for the 11th time in 2011. As with the previous competitions, a review of this year’s competition is certainly cause for celebration. The large number of entries from many countries and the high standard of work submitted confirm that the competition is taking the correct approach. Held for the first time in 1993, the competition aims to promote construction using textiles. The objective is to awaken the interest and enthusiasm of students for a method of construction which offers great potential for innovation and a wealth of opportunities for enriching the world of architecture as a whole. It is the students of today who will work with textiles and design the textile buildings of the future. As tomorrow’s architects, they will have a great influence on the appearance of our urban landscape. It is therefore important to promote their work and to give them the opportunity to work with new materials. The entries submitted provide impressive evidence of the opportunities offered by construction using textiles. A total of 12 projects received a prize.

Organizers: Techtextil, Messe Frankfurt and TensiNet Association  
 Jury: Nasrine Seraji (France -Chairwoman of the Jury),  
 Heidrun Bogner-Balz (Germany), Gert Eilbracht, (Austria),  
 Alex Heslop (U.K.), HG Merz (Germany) and  
 Werner Sobek (Germany)

The TensiNet Association sponsors this International Student Competition.

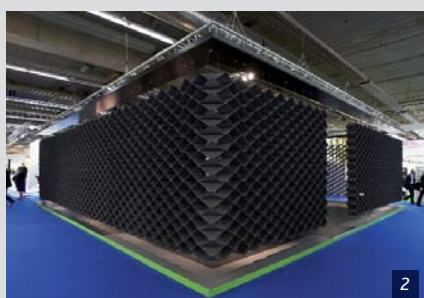
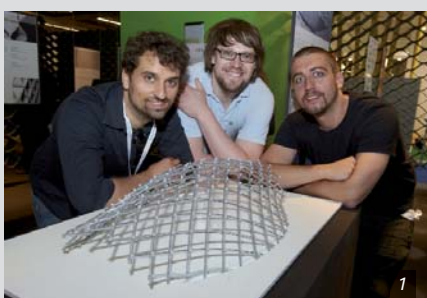

Figure 1. Category 1: Macro Architecture  
 „Plusminus Pneumatic Gridshell“ 1<sup>st</sup> Prize

Figure 2. Pavilion of Student Competition

As in previous years, the jury awarded prizes in four categories:

## Category 1: Macro Architecture 2 Awards

- 1<sup>st</sup> PRIZE: Plusminus Pneumatic Gridshell (Sebastian Kron, Nora Haase-Aschoff, Mathias Hackmann, Philipp Kuner, Julian Lutz, Fabian Pfeiffer)  
 2<sup>nd</sup> PRIZE: Tensegrity Ring (Diana Maritza Peña Villamil)

## Category 2: Micro Architecture 3 Awards

- 1<sup>st</sup> PRIZE: X-Change (Riva Fleur Vidal)  
 1<sup>st</sup> PRIZE: TS-1 textile selfsupporting (Andreas Moog)  
 1<sup>st</sup> PRIZE: Knitecture (Stefanie Powell)

## Category 3: Sustainability and Surface 3 Awards

- 1<sup>st</sup> PRIZE: KnitSkin (Annelie Asam, Sally Alejos)  
 2<sup>nd</sup> PRIZE: FLOW (Thorsten Klaus)  
 3<sup>th</sup> PRIZE: Double Layered Membrane (Elena Vlasceanu)

## Category 4: Composites and Hybrid Structures 2 Awards

- 2<sup>nd</sup> PRIZE: Monotex (Viktoria Darenberg, Leonard Chmielewski)  
 2<sup>nd</sup> PRIZE: Sound Adaptive Acoustic System (Mohammad Mustafa Kadiri)

In addition, two further prizes were awarded which were not related to any specific category.

## Honorable Mention

- Textile Wall (Lisa Spengler, Moa Hallgren)  
 Wandering Championships (Tomasz Kujawski)

Prof. Dr.-Ing. Werner Sobek